



# SPS 2

**Special Products Standard  
for Machine Graded Lumber**



June 2025



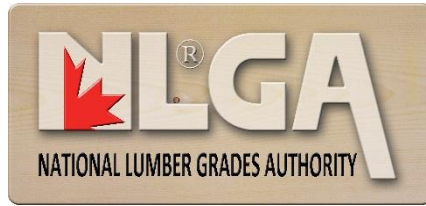

# **SPS 2**

## **SPECIAL PRODUCTS STANDARD**

### **FOR**

## **MACHINE GRADED LUMBER**

**EFFECTIVE: June 1, 2025**

**Supersedes All Previous Editions, Revisions, and Supplements**

**Approved by the Canadian Lumber Standards Accreditation Board – May 22, 2025**

**Approved by the American Lumber Standard Committee, Board of Review as complying  
with the ALSC Machine Graded Lumber Policy – April 3, 2025**

Published by the

**NATIONAL LUMBER GRADES AUTHORITY**

Ottawa, ON, Canada

[www.nlga.org](http://www.nlga.org)

© NATIONAL LUMBER GRADES AUTHORITY - 1978, 1982, 1987, 1994, 1997, 1998, 2000, 2002, 2003, 2004, 2005, 2006, 2008, 2009, 2010, 2013, 2017, 2019, 2024, 2025

**“All rights reserved.”** No part of this publication may be reproduced or stored in any material form (including photocopying, storing it in any medium by electronic means whether or not transiently or incidentally to such use of this publication) without the written permission of the copyright holder except in accordance with the provisions of the **“Copyright Act”**. Applications for the copyright holder’s written permission to produce any part of this publication must be addressed to the copyright holder.

**Warning:** The doing of any unauthorized act in relation to a copyrighted work may result in both civil claim for damages and criminal prosecution.



**TABLE OF CONTENTS**

<b>1.0</b>	<b>SCOPE</b>	<b>6</b>
1.1	PART A, PART B, AND PART C	6
1.2	NLGA STANDARD GRADING RULES	6
1.3	UNITS	6
1.4	DESIGN VALUES	6
1.5	INTERPRETATIONS	6
<b>2.0</b>	<b>DEFINITIONS &amp; REFERENCED PUBLICATIONS</b>	<b>6</b>
2.1	DEFINITIONS	6
2.2	REFERENCED PUBLICATIONS	8
<b>3.0</b>	<b>PRODUCT DESCRIPTION</b>	<b>9</b>
3.1	MACHINE STRESS-RATED LUMBER (MSR)	9
3.2	MACHINE EVALUATED LUMBER (MEL)	9
3.3	E-RATED STRUCTURAL LAM LUMBER	9
3.4	MSR/MEL TENSION LAM LUMBER	9
<b>4.0</b>	<b>GRADE DESCRIPTIONS</b>	<b>9</b>
<b>5.0</b>	<b>SPECIES AND STANDARD SIZES</b>	<b>10</b>
<b>6.0</b>	<b>VISUAL GRADING REQUIREMENTS</b>	<b>13</b>
6.1	MACHINE STRESS-RATED LUMBER (MSR)	13
6.2	MACHINE EVALUATED LUMBER (MEL)	13
6.3	E-LAM LUMBER	13
6.4	VISUAL QUALITY LEVEL (VQL) FOR MSR AND MEL	14
6.5	VISUAL GRADING REQUIREMENTS FOR THE UNTESTED PORTIONS OF MACHINE GRADED LUMBER	14
6.6	ALTERNATE VISUAL QUALITY LEVELS	14
<b>7.0</b>	<b>MECHANICAL PROPERTY REQUIREMENTS</b>	<b>15</b>
7.1	MEAN MODULUS OF ELASTICITY	15
7.2	MINIMUM MODULUS OF ELASTICITY	15
7.3	MODULUS OF RUPTURE	15
7.4	ULTIMATE TENSILE STRENGTH (UTS)	15
7.5	SPECIFIC GRAVITY	15
<b>8.0</b>	<b>PROPERTY EVALUATION PROCEDURES</b>	<b>16</b>
8.1	MODULUS OF ELASTICITY (E)	16
8.2	MODULUS OF RUPTURE (MOR)	16
8.3	ULTIMATE TENSILE STRENGTH (UTS)	16
8.4	SPECIFIC GRAVITY (SG)	16
8.5	ENVIRONMENTAL CONDITIONS	17
<b>9.0</b>	<b>GRADE STAMPING REQUIREMENTS</b>	<b>17</b>
<b>10.0</b>	<b>EQUIPMENT</b>	<b>18</b>
10.1	GRADING MACHINE	18
10.2	QUALITY CONTROL TEST EQUIPMENT	18
<b>11.0</b>	<b>QUALITY CONTROL MANUAL</b>	<b>18</b>
11.1	GENERAL	18
11.2	PREPARATION, REVISION AND APPROVAL	18
11.3	CONTENTS	19
<b>12.0</b>	<b>QUALIFICATION AND SAMPLING REQUIREMENTS</b>	<b>19</b>
12.1	INITIAL QUALIFICATION	19
12.2	QUALIFICATION SAMPLING	20
12.3	QUALIFICATION TESTING	20
12.4	ANALYSIS OF QUALIFICATION TESTS	20
12.5	INCREASED (DOUBLE) SAMPLING FOLLOWING QUALIFICATION	21
12.6	SUBSEQUENT QUALIFICATION	21
12.7	MACHINE ADJUSTMENT (FINE-TUNING) FOLLOWING QUALIFICATION	21
12.8	NON-PRODUCTION OF QUALIFIED GRADES	22
12.9	NOTIFICATION REQUIREMENTS FOR DISCONTINUANCE OF QUALITY CONTROL PROCEDURES	22
12.10	GRADING MACHINE MAJOR MAINTENANCE	22
<b>13.0</b>	<b>EQUIPMENT CALIBRATION</b>	<b>22</b>
13.1	GRADING MACHINE	22
13.2	TEST EQUIPMENT	22
13.3	CALIBRATION DEVICES	23
<b>14.0</b>	<b>QUALITY CONTROL REQUIREMENTS</b>	<b>23</b>
14.1	QUALITY CONTROL PROCEDURES	23

14.2	QUALITY CONTROL SAMPLING	23
14.3	QUALITY CONTROL TESTING	23
14.4	ANALYSIS OF QUALITY CONTROL TESTS	24
14.5	IDENTIFICATION AND TRACEABILITY	25
14.6	QUALITY CONTROL RECORDS	25
<b>15.0</b>	<b>RE-INSPECTION PROVISIONS</b>	<b>25</b>
15.1	GENERAL	25
<b>16.0</b>	<b>EU EXPORT REQUIREMENTS FOR MGL</b>	<b>26</b>
16.1	REFERENCED PUBLICATIONS	26
16.2	VISUAL GRADING REQUIREMENTS	27
16.3	GRADE STAMP REQUIREMENTS	28
16.4	MGL GRADE AND STRENGTH CLASS ASSIGNMENTS	28
16.5	RECORDS	29
16.6	ADDITIONAL QUALIFICATION AND QUALITY CONTROL REQUIREMENTS (EN 14081-2 & EN 14081-3)	29

**APPENDICES**

APPENDIX I - REFERENCE MODULUS OF ELASTICITY	30
APPENDIX II - CORRECTION FACTORS FOR EDGE MODULUS OF ELASTICITY	30
APPENDIX III - MECHANICAL PROPERTY DESCRIPTIONS	31
APPENDIX IV - CUSUM PARAMETERS FOR MOE QUALITY CONTROL	31
APPENDIX V - OUT-OF-CONTROL FLOW CHARTS FOR MGL VERIFICATION	32
APPENDIX VI - COMMENTARY ON QUALITY CONTROL SAMPLING FREQUENCY	38
APPENDIX VII - COMMENTARY ON INCREASED (DOUBLE) SAMPLING FREQUENCY	38
APPENDIX VIII - COMMENTARY ON CONTENTS OF A QUALITY CONTROL MANUAL	39
APPENDIX IX - CUSUM PARAMETERS FOR SPECIFIC GRAVITY CONTROL	39

**LIST OF TABLES**

TABLE 1 - STANDARD THICKNESS AND WIDTHS (FROM CSA O141 AND PS 20)	10
TABLE 2 - CHARACTERISTIC PROPERTY VALUES FOR MSR LUMBER GRADES	11
TABLE 3 - CHARACTERISTIC PROPERTY VALUES FOR MEL GRADES	12
TABLE 4 - E-RATED STRUCTURAL LAM AND MSR/MEL TENSION LAM LUMBER	12
TABLE 5 - SLOPE OF GRAIN LIMITS FOR UNTESTED PORTIONS OF MSR AND MEL LUMBER	13
TABLE 6 - STRENGTH REDUCING CHARACTERISTIC LIMITS FOR MSR, MEL, AND MSR/MEL TENSION LAM LUMBER	14
TABLE 7 - VISUAL REQUIREMENTS FOR THE UNTESTED PORTION OF MSR, MEL, AND MSR/MEL TENSION LAM LUMBER	14
TABLE 8 - RECOMMENDED E-LAM FLAT-WISE LS-E TEST LOADS	16
TABLE 9 - GRADE STAMPING REQUIREMENTS BY MGL PRODUCT	17
TABLE 10 - PROPERTY TEST REQUIREMENTS FOR QUALIFICATION AND DAILY QUALITY CONTROL BY MGL PRODUCT	21
TABLE 11 - TEST EQUIPMENT SPOT-CHECK FREQUENCY	23
TABLE 12 - CONFORMANCE CRITERIA FOR MSR, E-LAM AND MSR TENSION LAM LUMBER RE-INSPECTION	26
TABLE 13 - CONFORMANCE CRITERIA FOR MEL & MEL TENSION LAM RE-INSPECTION	26
TABLE 14 - CEN SIZE TOLERANCES	27
TABLE 15 - CEN WARP (DISTORTION) LIMITS	27
TABLE 16 - CEN PERMITTED LENGTHS OF SHAKE, CHECKS, AND SPLITS (FISSURES)	28
TABLE 17 - CEN STRENGTH CLASS ASSIGNMENTS	29
TABLE 18 - CORRECTION FACTORS FOR MOE	30
TABLE 19 - CUSUM PARAMETERS FOR MGL CATEGORIES	31
TABLE 20 - CUSUM PARAMETERS FOR MONITORING SPECIFIC GRAVITY	39

**LIST OF FIGURES**

FIGURE 1 - EXAMPLES OF TYPICAL NORTH AMERICAN / EU GRADE STAMPS FOR MACHINE GRADED LUMBER	28
FIGURE 2 - VERIFICATION DECISION FLOWCHART	32
FIGURE 3 - RESULT A DECISION FLOWCHART	33
FIGURE 4 - RESULT B DECISION FLOWCHART	34
FIGURE 5 - RESULT C DECISION FLOWCHART	35
FIGURE 6 - ACTION 1 DECISION FLOWCHART	36
FIGURE 7 - ACTION 2 DECISION FLOWCHART	36
FIGURE 8 - ACTION 3 DECISION FLOWCHART	37

## PREFACE

This Special Products Standard is amended and updated from time to time. The following is a summary of SPS 2 revisions.

**a) Revised Sections Effective December 1, 2004**

- Sections 6.1, 6.2, and 9.1

**b) Revised Sections Effective December 1, 2005**

- Sections 6.1 and 6.2

**c) Revised Sections Effective December 1, 2006**

- Sections 1.1, 6.1, 13.1, and 14.4.2
- Flowchart Action 1
- New Part C

**d) Editorially Revised Sections May 24, 2008**

- Sections 16.2.3 and 16.2.5

**e) Editorially Revised Part C - June 1, 2009**

- New Section 16.4.1
- Table 17 – revised

**f) Editorially Revised Part C – Dec. 1, 2009**

- Table 17 – revised

**g) Revised Sections Effective July 14, 2010**

- Section 12.8

**h) Revised Sections Effective November 1, 2010**

- Section 2.1 - added Spot-Check definition
- Section 2.2 - updated References
- Section 13.2 and 13.3 – Added “Spot-check” references

**i) Revised Sections Effective February 1, 2013**

- Table 11 – revised
- Table 18 footnote – revised

**j) Revised Sections Effective Feb 15, 2017**

- Section 2.1 – added definitions for Independent Certification Agency and Independent Calibration Laboratory
- Section 2.2 – updated and added references
- Section 13.2 – revised
- New Section 13.2.1 – Independent Calibration Laboratory Reporting Requirements
- Section 13.3 – Calibration Devices - revisions
- Section 14.6 – Quality Control Records - revisions
- Table 9 – Grade Stamping (Marking) Requirements - revisions

**k) Revised Sections Effective April 1, 2019**

- Section 2.1 – minor edits and add definition for Major Maintenance
- Section 2.2 – updated references
- Section 6.0 – clarified and reorganized sub-sections.
- Section 11.2.3 – added requirements for QC Manual related to Major Maintenance
- Section 12.10 – added new section for Grading Machine Major Maintenance procedures
- Section 14 – updated the term “calibration” with “spot-check” for test equipment as per changes to Section 13 in Nov 2010 and Feb 2013
- Section 14.2.1 – added note to QC sampling method
- Section 16 – updated EU Export Requirements
- Appendix V – corrections and clarifications to Flowcharts

**l) Revised Sections Effective February 1, 2024**

- Incorporated SPS 2 Ratified Responses into the Standard where applicable
- Section 1.5 – added new section regarding interpretation of the Standard
- Section 2.2 – updated and added references
- Section 11.0 – updated QC Manual requirements
- Section 16 – updated EU Export Requirements
- Appendix V – added and updated flowcharts
- New Appendices VI, VII, and VIII – added commentary on sampling frequencies and contents of a QC Manual
- New Appendix IX – added CUSUM table for Specific Gravity control

**m) Revised Sections Effective June 1, 2025**

- Section 2.0 – updated and clarified definitions and references
- Tables 2a, 2b, 3, and 20 – revised Hem-Fir (N) specific gravity values
- Added changes to metric sizes to align with PS 20

## 1.0 SCOPE

### 1.1 PART A, PART B, AND PART C

This Standard for Machine Graded Lumber (MGL) consists of three parts.

#### PART A - PRODUCT SPECIFICATIONS

This Part specifies grade characteristics, standard sizes, visual grading and mechanical property requirements, property evaluation procedures, and grade stamping (marking) requirements for machine stress-rated lumber (MSR), machine evaluated lumber (MEL), and two types of E-LAM: E-rated structural laminations lumber and MSR/MEL tension lam lumber.

#### PART B - QUALIFICATION AND QUALITY CONTROL REQUIREMENTS

This Part specifies minimum qualifications and quality control requirements for a facility producing MSR, MEL or E-LAM lumber in accordance with the requirements of Part A.

#### PART C - EUROPEAN UNION EXPORT REQUIREMENTS

This Part specifies the additional requirements for MGL produced under this Standard to comply with European Standards regulations and to be able to apply CE marking to MGL grade stamps.

### 1.2 NLGA STANDARD GRADING RULES

This Standard shall be used in conjunction with and forms part of the National Lumber Grades Authority Standard Grading Rules for Canadian Lumber (NLGA Standard Grading Rules).

**Note:** Paragraph numbers (NLGA Para. X) referenced in this Standard refer to the numbered paragraphs in the NLGA Standard Grading Rules.

### 1.3 UNITS

This Standard states values in inch-pound (imperial) units. The equivalent SI (metric) values, given in parentheses, are provided for information only. In case of discrepancy, the values stated in imperial units shall take precedence.

### 1.4 DESIGN VALUES

For use in Canada, design values are assigned to the grades shown in Tables 2 and 3 by the CSA Technical Committee on Engineering Design in Wood. Design values are published in CSA O86 – Engineering design in wood.

For use in the U.S., design values are developed in accordance with ASTM D6570 and published in NLGA Para. 910 and in the American Wood Council (AWC) National Design Specification (NDS) Supplement.

### 1.5 INTERPRETATIONS

The interpretation of the provisions in this Standard are vested in NLGA.

## 2.0 DEFINITIONS & REFERENCED PUBLICATIONS

### 2.1 DEFINITIONS

The following definitions shall apply to this Standard.

**AGENCY:** organization accredited by the Canadian Lumber Standards Accreditation Board (CLSAB) and/or the American Lumber Standard Committee (ALSC) Board of Review engaged in the grading, grade stamping and/or certification of lumber or who certifies facilities to grade and place a grade stamp upon lumber.

**AGENCY SUPERVISOR:** representative of the Agency who is approved by the Agency to inspect facilities producing MSR, MEL and/or E-LAM lumber.

**AGENCY VERIFICATION:** specific set of procedures used by an Agency to verify that an item of grade- stamped (marked) MSR, MEL or E-LAM lumber conforms to the requirements of this Standard and the NLGA Standard Grading Rules.

**CALIBRATION:** procedure of comparing two instruments, measuring devices or standards, one of which is of known accuracy traceable to a nationally recognised standard.

**CHARACTERISTIC PROPERTY VALUE:** value corresponding to a percentile in the assumed statistical distribution of a particular property of the material.

**Note:** For the purpose of this Standard, characteristic strength values (i.e., MOR and UTS) are defined as the population 5th percentile values obtained under a short-term test load.

Characteristic stiffness values (i.e.,  $E_{5th}$  and  $E$ ) are defined as the population 5th percentile and mean value, respectively, obtained under a short-term test load.

The characteristic specific gravity is defined as the population mean value.

**CONTROL CHARTS:** reports or records used to monitor the variation between the process quality level and a predetermined conformance quality level, and to indicate when changes in the process are required to bring the process back into an “In-Control” state as defined by the conformance quality level.



**E-LAM LUMBER:** two types of E-LAM lumber are specified in this Standard:

- a) **E-RATED STRUCTURAL LAMINATIONS LUMBER:** lumber that has been non-destructively evaluated by a grading machine and meets the E-Rated Structural Lam Lumber requirements in Section 3.3.
- b) **MSR/MEL TENSION LAMINATIONS LUMBER:** lumber that has been non-destructively evaluated by a grading machine and meets the MSR/MEL tension lam lumber requirements in Section 3.4.

**EVALUATION:** assessment of a facility's manufacturing process and its quality control programs to determine whether it can produce an item that meets the requirements of this Standard.

**FACILITY:** manufacturing plant that produces MSR, MEL and/or E-LAM lumber.

**GRADING MACHINE:** equipment used to sort lumber into mechanical property classes (e.g., stiffness classes) and approved by CLSAB and/or ALSA.

**GRADE STAMP:** grade identification applied on a piece of machine-graded lumber which includes the applicable information required in Section 9.

*Note: The grade stamp (also referred to as a grade mark) indicates that the grading process meets the requirements of the Agency's qualification and quality control procedures.*

**HALF-WEIGHT:** weight measured at one support when a beam (assumed to have a uniform weight per unit length) is symmetrically supported.

**IN-CONTROL:** state in which on-going quality control testing indicates that the production process continues to meet the mechanical property requirements of this Standard.

**INDEPENDENT CALIBRATION LABORATORY:** organization that performs testing to verify and establish results for test equipment, operating in accordance with ISO/IEC 17025 and accredited by an Accreditation Body listed under the ILAC Mutual Recognition Agreement (ILAC MRA).

**INDEPENDENT CERTIFICATION AGENCY:** organization operating in accordance with ISO/IEC 17065 and accredited by an Accreditation Body listed under the International Accreditation Forum (IAF).

**INSPECTION:** examination, measurement and/or testing of the properties of an item to ensure they meet the quality control requirements of this Standard.

**ITEM:** lumber of a given grade, size (without reference to length), species or species combination, and moisture content.

**LONG-SPAN MODULUS OF ELASTICITY (LS E):** modulus of elasticity measured in a flat-wise test mode, using centre-point loading and a span-to-depth ratio of 100.

**MACHINE EVALUATED LUMBER (MEL):** lumber that has been non-destructively evaluated by a grading machine to predict specific mechanical properties and meets the MEL requirements in Section 3.2.

**MACHINE STRESS-RATED (MSR) LUMBER:** lumber that has been non-destructively evaluated by a grading machine and meets the MSR requirements in Section 3.1.

**MAJOR MAINTENANCE:** maintenance activity that could cause the grading machine to measure or interpret the indicating property differently than when the grading machine last underwent initial or subsequent qualification.

*Note: This includes actions such as, but not limited to, structural or moving component changes; repairs due to failure of a machine component; load cell, stress-wave or acoustic device replacement; and software upgrades.*

**MINIMUM MODULUS OF ELASTICITY:** characteristic fifth (5<sup>th</sup>) percentile modulus of elasticity ( $E_{5th}$ ).

**MODULUS OF ELASTICITY (MOE or E):** ratio of stress to corresponding strain below the proportional limit.

*Note: In this Standard, the modulus of elasticity is determined in edgewise bending at a span of 21 times the depth and based on ASTM D198. The surfaced size (net finished size) is used in computing the modulus of elasticity.*

**NON-CONFORMANCE:** deficiency in a property, documentation or procedure that renders the quality of an item not to be in adherence to specified requirements of this Standard and therefore unacceptable.

*Note: Examples that may cause non-conformance are physical defects, test failures, incorrect or inadequate documentation, and deviations from prescribed processing, inspection, or test procedures.*

**OUT-OF-CONTROL:** state in which on-going quality control testing indicates that the production process does not meet the mechanical property requirements of this Standard.

**QUALITY CONTROL:** set of procedures that provide a means of measuring and regulating the characteristics of an item to specified requirements.

**QUALITY CONTROL MANUAL:** document which sets forth a specific set of instructions to describe the quality control functions to be carried out in the production of MSR, E-LAM and/or MEL at a specified facility.

**RANDOM SAMPLING:** procedure by which a representative sample is generated from a population.

**SAMPLING FREQUENCY:** three types of sampling frequencies are used in this Standard:

a) **QUALITY CONTROL SAMPLING:** random sampling undertaken to generate one 5-specimen sample from every 4 hours or less of ongoing production.

*Note: See APPENDIX VI for commentary on quality control sampling scenarios.*

b) **INCREASED (DOUBLE) SAMPLING:** random sampling undertaken to generate two 5-specimen samples from every four hours or less of production, for a period of three production shifts.

*Note: See APPENDIX VII for commentary on increased (double) sampling scenarios.*

c) **INTENSIVE SAMPLING:** random sampling undertaken to immediately generate six 5-specimen samples, sequentially identified, from production of an item.

**SPECIFIC GRAVITY:** weight of a substance relative to the weight of an equal volume of water.

*Note: Specific gravity (SG) is also commonly known as relative density. The SG is based on the mass and volume of the wood at oven-dry moisture content.*

**SPECIMEN:** piece of MSR, MEL or E-LAM lumber randomly selected from production for purposes of quality control, quality verification testing and any subsequent analysis.

**SPOT CHECK:** verification that the test equipment is still within calibration tolerances.

**TEST EQUIPMENT:** equipment used by the facility to determine the modulus of elasticity (E), long-span modulus of elasticity (LS E), modulus of rupture (MOR), and/or where applicable, the ultimate tensile strength (UTS) and specific gravity (G) to determine conformance to the specified requirements of this Standard.

**TEST LOAD:** load that will induce a stress that corresponds to the characteristic property value for the grade under consideration.

## 2.2 REFERENCED PUBLICATIONS

**AITC** (American Institute of Timber Construction)

**117-2020** Standard Specifications for Structural Glued Laminated Timber of Softwood Species

**ALSC** (American Lumber Standard Committee, Incorporated)

**Machine Graded Lumber Policy** (2019)

**ASTM**

**D198-22** Standard Methods of Static Tests of Timbers in Structural Sizes

**D245-22** Standard Practice for Establishing Structural Grades and Related Allowable Properties for Visually Graded Lumber

**D2395-17 (2022)** Standard Test Methods for Density and Specific Gravity (Relative Density) of Wood and Wood-Based Materials

**D2915-17 (2022)** Standard Practice for Sampling and Data-Analysis for Structural Wood and Wood-Based Products

**D4444-13 (2018)** Standard Test Method for Laboratory Standardization and Calibration of Hand-Held Moisture Meters

**D6570-18a (2023)e1** Standard Practice for Assigning Allowable Properties for Mechanically Graded Lumber

**D7438-20** Standard Practice for Field Calibration and Application of Hand-Held Moisture Meters

**E4-24** Standard Practices for Force Verification of Testing Machines

**E74-18e1** Standard Practice for Calibration and Verification for Force-Measuring Instruments

**E83-23** Standard Practice for Verification and Classification of Extensometer Systems

**CLSAB** (Canadian Lumber Standards Accreditation Board)

**CLSAB Regulations** (2024)

**CSA Group**

**CSA O86:24** Engineering design in wood

**CSA O141:23** Canadian standard lumber

**ISO**

**ISO/IEC 17025:2017 (c2023)** General requirements for the competence of testing and calibration laboratories

**ISO/IEC 17065:2012 (c2024)** Conformity assessment – requirements for bodies certifying products, processes and services

**NIST** (National Institute of Standards and Technology, U.S. Department of Commerce)

**PS 20:25** American Softwood Lumber Standard

**NLGA** (National Lumber Grades Authority)

**Standard Grading Rules for Canadian Lumber** (2022)

## PART A - GENERAL SPECIFICATIONS FOR MACHINE GRADED LUMBER

### 3.0 PRODUCT DESCRIPTION

Machine Graded Lumber (MGL) is lumber that has been non-destructively evaluated by a grading machine to predict specific mechanical properties.

MGL in the following categories is produced from solid-sawn lumber.

**Note:** For fingerjoined MGL, see NLGA SPS 4 – Special Products Standard for Fingerjoined Machine Graded Lumber.

#### 3.1 MACHINE STRESS-RATED LUMBER (MSR)

Machine Stress-Rated (MSR) lumber is distinguished from visually graded lumber in that each piece is non-destructively tested and marked to indicate the grade classification (**Fb-E**).

MSR lumber shall meet the visual requirements as set forth in this Standard and NLGA Para. 128b.

Qualification and subsequent quality control of the modulus of elasticity (E) and bending strength ( $F_b$ ) are required for each item.

Specific gravity (SG) qualification and subsequent quality control are required when the SG value exceeds the value assigned to the grade set forth in Table 2.

When a S-P-F grade E ( $E_g$ ) of 2.0E is run in conjunction with a higher E grade(s) then SG shall be quality controlled for the 2.0E grade.

When applicable, qualification and subsequent quality control for ultimate tensile strength (UTS) are required as outlined in Table 2b.

#### 3.2 MACHINE EVALUATED LUMBER (MEL)

Machine Evaluated Lumber (MEL) is distinguished from visually graded lumber in that each piece is non-destructively tested and marked to indicate a strength classification code (**M-xx**).

MEL shall meet the visual requirements described in this Standard and NLGA Para. 128c.

Qualification and subsequent quality control are required for each of the following properties: modulus of elasticity (E), bending strength ( $F_b$ ) and tensile strength ( $F_t$ ).

Specific gravity (SG) qualification and subsequent quality control are required when the SG value exceeds the value assigned to the grade set forth in Table 3.

When a Spruce-Pine-Fir (S-P-F) grade E ( $E_g$ ) of 2.0E is run in conjunction with a higher E grade(s), then SG shall be quality controlled for the 2.0E grade.

#### 3.3 E-RATED STRUCTURAL LAM LUMBER

E-Rated structural lam lumber is distinguished from visually graded lumber in that each piece is non-destructively tested and marked to indicate the long-span flat-wise grade E (**LS E**) classification.

E-Rated structural lam lumber shall meet the visual requirements as set forth in this Standard and NLGA Para. 128d.

Qualification and subsequent quality control for the long-span flat-wise grade E is required for each item.

**Note:** Moisture content limits for E-Rated Structural Lam lumber is subject to special agreement.

#### 3.4 MSR/MEL TENSION LAM LUMBER

MSR/MEL tension lam lumber is distinguished from visually graded lumber in that each piece is non-destructively tested and marked to indicate the applicable MSR / MEL / LS E classification and the tensile strength ( $F_t$ ) designation.

MSR/MEL tension lam lumber shall meet the visual requirements of this Standard and NLGA Para. 128e.

Qualification and subsequent quality control are required for each of the following properties: edge modulus of elasticity (E), long-span flat-wise modulus of elasticity (LS E), bending strength ( $F_b$ ) and tensile strength ( $F_t$ ).

**Note:** Moisture content limits for MSR/MEL tension lam lumber is subject to special agreement.

### 4.0 GRADE DESCRIPTIONS

MSR lumber grades are designated by an Fb-E classification system, where Fb is the assigned bending strength class and E is the assigned modulus of elasticity for the grade. The grades of MSR lumber produced in accordance with this Standard are listed in Table 2.

MEL grades are identified by a grade code that references a specific set of characteristic property values. The grades of MEL produced in accordance with this Standard are listed in Table 3.

E-Rated structural lam lumber grades are designated by an E-LAM classification system, where the E rating is the average long-span flat-wise E (LS E) value expressed in millions of pounds per square inch. The grades of E-Rated structural lam lumber produced in accordance with this Standard are listed in Table 4.

MSR/MEL tension lam grades are identified by the MSR, MEL and E-LAM classification system with the addition of the tensile strength ( $F_t$ ) identification. The grades of MSR/MEL tension lam lumber are listed in Table 2 and Table 3.

**Note:** Subject to revision of NLGA Para. 910 for use in the U.S., CSA O86 for use in Canada, and Tables 2, 3, or 4 of this Standard, MSR, MEL and E-LAM grades may be produced in other characteristic property value combinations provided qualification procedures and subsequent quality control verification assure the assignment is appropriate.

**5.0 SPECIES AND STANDARD SIZES**

Machine grading may be applied to lumber from any species or species group recognized in NLGA Paras. 7 and 7a.

Standard thickness and widths for MSR, MEL and E-LAM lumber produced in accordance with this Standard are shown in Table 1. Other thickness and widths may be used upon qualification.

Standard lengths are 6 feet (1.83 m) and longer in multiples of 1 foot (0.30 m).

**Note:** Non-standard lengths may be produced under buyer-seller agreement.

Cross-cutting of MSR/MEL lumber is permitted without re-evaluating the cross-cut pieces by a grading machine, provided:

- a) The resulting pieces meet the visual requirements of the grade,
- b) The resulting packages are labelled as to the date and shift of the original production,
- c) No further sorting or withdrawal of pieces is permitted, and
- d) Cross-cutting is carried out under the authorization of the producing facility.

**TABLE 1 - STANDARD THICKNESS AND WIDTHS (FROM CSA O141 AND PS 20)**

Nominal Dimension	Specified Dimension			
	inches		mm	
	Dry	Green	Dry	Green
<b>Thickness</b>				
<b>1</b>	3/4	25/32	19.1	19.8
<b>1-1/4</b>	1	1-1/32	25.4	26.2
<b>1-1/2</b>	1-1/4	1-9/32	31.8	32.5
<b>2</b>	1-1/2	1-9/16	38.1	39.7
<b>Width</b>				
<b>2</b>	1-1/2	1-9/16	38.1	39.7
<b>3</b>	2-1/2	2-9/16	63.5	65.1
<b>4</b>	3-1/2	3-9/16	88.9	90.5
<b>5</b>	4-1/2	4-5/8	114.3	117.5
<b>6</b>	5-1/2	5-5/8	139.7	142.9
<b>8</b>	7-1/4	7-1/2	184.2	190.5
<b>10</b>	9-1/4	9-1/2	235.0	241.3
<b>12</b>	11-1/4	11-1/2	285.8	292.1

TABLE 2 - CHARACTERISTIC PROPERTY VALUES FOR MSR LUMBER GRADES

TABLE 2a) The following MSR grades do not require tension testing except when used for MSR/MEL tension lam lumber.										
MSR GRADES	MEAN MODULUS OF ELASTICITY		MINIMUM MODULUS OF ELASTICITY		MODULUS OF RUPTURE		ULTIMATE TENSILE STRENGTH		COMPRESSION PARALLEL TO GRAIN	
	(psi)	(MPa)	(psi)	(MPa)	(psi)	(MPa)	(psi)	(MPa)	(psi)	(MPa)
1200Fb - 1.2E	1,200,000	8,274	984,000	6,784	2,520	17.4	1,260	8.7	2,660	18.3
1350Fb - 1.3E	1,300,000	8,963	1,066,000	7,350	2,835	19.6	1,575	10.9	3,040	21.0
1450Fb - 1.3E	1,300,000	8,963	1,066,000	7,350	3,045	21.0	1,680	11.6	3,088	21.3
1500Fb - 1.4E	1,400,000	9,653	1,148,000	7,915	3,150	21.7	1,890	13.0	3,135	21.6
1650Fb - 1.5E	1,500,000	10,342	1,230,000	8,481	3,465	23.9	2,142	14.8	3,230	22.3
1800Fb - 1.6E	1,600,000	11,032	1,312,000	9,046	3,780	26.1	2,467	17.0	3,325	22.9
1950Fb - 1.7E	1,700,000	11,721	1,394,000	9,611	4,095	28.2	2,887	19.9	3,420	23.6
2100Fb - 1.8E	1,800,000	12,411	1,476,000	10,177	4,410	30.4	3,307	22.8	3,562	24.6
2250Fb - 1.9E	1,900,000	13,100	1,558,000	10,742	4,725	32.6	3,675	25.3	3,658	25.2
2400Fb - 2.0E	2,000,000	13,789	1,640,000	11,307	5,040	34.7	4,042	27.9	3,752	25.9
2550Fb - 2.1E	2,100,000	14,479	1,722,000	11,873	5,355	36.9	4,305	29.7	3,848	26.5
2700Fb - 2.2E	2,200,000	15,168	1,804,000	12,438	5,670	39.1	4,515	31.1	3,990	27.5
2850Fb - 2.3E	2,300,000	15,858	1,886,000	13,003	5,985	41.3	4,830	33.3	4,085	28.1
3000Fb - 2.4E	2,400,000	16,547	1,968,000	13,569	6,300	43.4	5,040	34.8	4,180	28.8
Specific gravity values are assigned as follows (See Section 3.1):										
D Fir-L (N)	SG values are a function of the grade E 1.2E to 1.9E SG = 0.49 2.0E to 2.2E SG = 0.53 2.3E and higher SG = 0.57				S-P-F		SG values are a function of the grade E 1.2E to 1.7E SG = 0.42 1.8E to 1.9E SG = 0.46 2.0E and higher SG = 0.50			
Hem-Fir (N)	SG = 0.44 (all grades)				North Species		SG = 0.35 (all grades)			

TABLE 2b) The following MSR grades provide a modulus of elasticity level with a corresponding higher strength requirement. For these MSR grades, qualification and daily quality control for tensile strength are required.										
MSR GRADES	MEAN MODULUS OF ELASTICITY		MINIMUM MODULUS OF ELASTICITY		MODULUS OF RUPTURE		ULTIMATE TENSILE STRENGTH		COMPRESSION PARALLEL TO GRAIN	
	(psi)	(MPa)	(psi)	(MPa)	(psi)	(MPa)	(psi)	(MPa)	(psi)	(MPa)
1400Fb - 1.2E	1,200,000	8,274	984,000	6,784	2,940	20.3	1,680	11.6	3,040	21.0
1600Fb - 1.4E	1,400,000	9,653	1,148,000	7,915	3,360	23.2	1,995	13.8	3,183	22.0
1650Fb - 1.3E	1,300,000	8,963	1,066,000	7,350	3,465	23.9	2,142	14.8	3,230	22.3
1800Fb - 1.5E	1,500,000	10,342	1,230,000	8,481	3,780	26.1	2,730	18.8	3,325	22.9
2000Fb - 1.6E	1,600,000	11,032	1,312,000	9,046	4,200	28.9	2,730	18.8	3,467	23.9
2250Fb - 1.7E	1,700,000	11,721	1,394,000	9,611	4,725	32.6	3,675	25.3	3,658	25.2
2250Fb - 1.8E	1,800,000	12,411	1,476,000	10,177	4,725	32.6	3,675	25.3	3,658	25.2
2400Fb - 1.8E	1,800,000	12,411	1,476,000	10,177	5,040	34.7	4,042	27.9	3,752	25.9
Specific gravity values are assigned as follows (See Section 3.1):										
D Fir-L (N)	SG values are a function of the grade E 1.2E to 1.9E SG = 0.49 2.0E to 2.2E SG = 0.53 2.3E and higher SG = 0.57				S-P-F		SG values are a function of the grade E 1.2E to 1.7E SG = 0.42 1.8E to 1.9E SG = 0.46 2.0E and higher SG = 0.50			
Hem-Fir (N)	SG = 0.44 (all grades)				North Species		SG = 0.35 (all grades)			

TABLE 3 - CHARACTERISTIC PROPERTY VALUES FOR MEL GRADES

MEL GRADES	MEAN MODULUS OF ELASTICITY		MINIMUM MODULUS OF ELASTICITY		MODULUS OF RUPTURE		ULTIMATE TENSILE STRENGTH		COMPRESSION PARALLEL TO GRAIN	
	(psi)	(MPa)	(psi)	(MPa)	(psi)	(MPa)	(psi)	(MPa)	(psi)	(MPa)
M-10	1,200,000	8,274	900,000	6,206	2,940	20.3	1,680	11.6	3,040	21.0
M-11	1,500,000	10,342	1,125,000	7,758	3,255	22.4	1,785	12.3	3,135	21.6
M-12	1,600,000	11,032	1,200,000	8,275	3,360	23.2	1,785	12.3	3,230	22.3
M-13	1,400,000	9,653	1,050,000	7,241	3,360	23.2	1,995	13.8	3,230	22.3
M-14	1,700,000	11,721	1,275,000	8,793	3,780	26.1	2,100	14.5	3,325	22.9
M-15	1,500,000	10,342	1,125,000	7,758	3,780	26.1	2,310	15.9	3,325	22.9
M-18	1,800,000	12,411	1,350,000	9,310	4,200	29.0	2,520	17.4	3,515	24.2
M-19	1,600,000	11,032	1,200,000	8,275	4,200	29.0	2,730	18.8	3,515	24.2
M-21	1,900,000	13,100	1,425,000	9,827	4,830	33.3	2,940	20.3	3,705	25.6
M-22	1,700,000	11,721	1,275,000	8,793	4,935	34.0	3,150	21.7	3,705	25.6
M-23	1,800,000	12,411	1,350,000	9,310	5,040	34.7	3,990	27.5	3,800	26.2
M-24	1,900,000	13,100	1,425,000	9,827	5,670	39.1	3,780	26.1	3,990	27.5
M-25	2,200,000	15,168	1,650,000	11,376	5,775	39.8	4,200	29.0	3,990	27.5
M-26	2,000,000	13,789	1,500,000	10,344	5,880	40.6	3,780	26.1	4,085	28.2
Specific gravity values are assigned as follows (See Section 3.2):										
D Fir-L (N)	SG values are a function of the grade E				S-P-F	SG values are a function of the grade E				
	1.2E to 1.9E		SG = 0.49			1.2E to 1.7E		SG = 0.42		
	2.0E to 2.2E		SG = 0.53			1.8E to 1.9E		SG = 0.46		
	2.3E and higher		SG = 0.57			2.0E and higher		SG = 0.50		
Hem-Fir (N)	SG = 0.44 (all grades)				North Species	SG = 0.35 (all grades)				

TABLE 4 - E-RATED STRUCTURAL LAM AND MSR/MEL TENSION LAM LUMBER

LONG SPAN MODULUS OF ELASTICITY				
Grade	Mean Modulus of Elasticity		Minimum Modulus of Elasticity	
	(psi)	(MPa)	(psi)	(MPa)
2.6E LAM	2,600,000	17,926	2,260,000	15,586
2.5E LAM	2,500,000	17,236	2,160,000	14,897
2.4E LAM	2,400,000	16,547	2,060,000	14,207
2.3E LAM	2,300,000	15,858	1,960,000	13,517
2.2E LAM	2,200,000	15,168	1,860,000	12,828
2.1E LAM	2,100,000	14,479	1,770,000	12,204
2.0E LAM	2,000,000	13,789	1,670,000	11,517
1.9E LAM	1,900,000	13,100	1,580,000	10,897
1.8E LAM	1,800,000	12,411	1,480,000	10,207
1.7E LAM	1,700,000	11,721	1,390,000	9,586
1.6E LAM	1,600,000	11,032	1,300,000	8,966
1.5E LAM	1,500,000	10,342	1,210,000	8,345



**6.0 VISUAL GRADING REQUIREMENTS**

**6.1 MACHINE STRESS-RATED LUMBER (MSR)**

Machine stress-rated lumber shall be well manufactured and visually graded to limit defined characteristics even though the actual strength may not be affected.

Characteristics and limiting provisions shall be:

**Checks:** Seasoning checks not limited. Through checks at ends are limited as splits.

**Insect Holes:** Treat the same as NO. 2 dimension lumber.

**Manufacture:** Standard F. See NLGA Para. 722f.

**Saw Cuts:** Generally, no saw cuts shall be permitted.

**Shake:** If through at ends, limited as splits. If away from ends, through shakes up to 2' long, well separated. If not through, single shakes shall not exceed 3 feet or 1/4 the length, whichever is the greater.

**Skip:** Hit and miss, with a maximum of 5% of the pieces containing hit or miss or heavy skip 2 feet or less in length. See NLGA Paras. 720e, 720f, and 720g.

**Slope of Grain:** For grading machines not evaluating slope of grain, the limitation on the general slope of grain is based on the Fb designation assigned to the grade as listed in Table 5.

*Note: Machines that measure MOE by deflection, indirectly evaluate slope of grain.*

**Splits:** Equal in length to 1-1/2 times the width of the piece.

**Timber breaks:** Not permitted.

**Unsound Wood:** Limited to a spot 1/12 the width and 2 inches in length or equivalent smaller.

**Wane:** 1/3 the thickness and 1/3 the width, full length, or equivalent on each face, provided that wane does not exceed 2/3 thickness or 1/2 the width for up to 1/4 the length. See NLGA Para. 750.

**Optional "1W" Wane Limitations:** 1/4 the thickness and 1/4 the width full length, or equivalent on each face, provided that wane does not exceed 1/2 the thickness or 1/3 width for up to 1/4 the length. See NLGA Para. 750.

**Warp:** Light. See NLGA Para. 752.

**White Specks:** Firm, 1/3 face or equivalent.

**6.2 MACHINE EVALUATED LUMBER (MEL)**

Machine evaluated lumber shall be well manufactured and visually graded to limit defined characteristics even though the actual strength may not be affected.

Characteristics and limiting provisions shall be:

**Checks:** Seasoning checks not limited; through checks at ends are limited as splits.

**Insect Holes:** Treat the same as NO. 2 dimension lumber.

**Manufacture:** Standard F. See NLGA Para. 722f.

**Saw Cuts:** Generally, no saw cuts shall be permitted.

**Shake:** If through at ends, limited as splits - away from ends through shakes up to 2 feet long, well separated. If not through, single shakes shall not exceed 3 feet long or 1/4 the length, whichever is greater.

**Skip:** Hit and miss, with a maximum of 5% of the pieces containing hit or miss or heavy skip 2 feet or less in length. See NLGA Paras. 720e, 720f, and 720g.

**Slope of Grain:** For grading machines not evaluating slope of grain, the limitation on the general slope of grain is based on the Fb designation assigned to the grade as listed in Table 5.

*Note: Machines that measure MOE by deflection indirectly evaluate slope of grain.*

**Splits:** Equal in length to 1-1/2 times the width of the piece.

**Timber breaks:** Not permitted.

**Unsound Wood:** Limited to a spot 1/12 the width and 2 inches in length or equivalent smaller.

**Wane:** 1/3 the thickness and 1/3 the width full length, or equivalent on each face provided that wane does not exceed 2/3 thickness or 1/2 the width for up to 1/4 length. See NLGA Para. 750.

**Optional "1W" Wane Limitations:** 1/4 the thickness and 1/4 the width full length, or equivalent on each face, provided that wane does not exceed 1/2 the thickness or 1/3 width for up to 1/4 the length. See NLGA Para. 750.

**Warp:** Light. See NLGA Para. 752.

**White Specks:** Firm, 1/3 face or equivalent.

**TABLE 5 - SLOPE OF GRAIN LIMITS FOR UNTESTED PORTIONS OF MSR AND MEL LUMBER**

Slope of Grain	Fb Designation
1 in 8	≤ 1450
1 in 10	1500 to 2050
1 in 12	≥ 2100

**6.3 E-LAM LUMBER**

E-LAM lumber shall be well manufactured and visually graded to limit defined characteristics even though the actual strength may not be affected.

**6.3.1 E-RATED STRUCTURAL LAM LUMBER**

Characteristics and limiting provisions shall be:

**Checks:** Seasoning checks not limited. Through checks on ends are limited as splits.

**Knots:** Knots may be sound, unsound, or not firmly fixed. A knot or knots shall not occupy more than 1/2 the cross-section. A knot of the permitted size may be anywhere on the piece.

**Holes:** Knot holes are interchangeable with knots in size and spacing. Other holes permitted if no more damaging in effect than the allowable knot hole.

**Manufacture:** Standard C. See NLGA Para. 722c.

**Pitch or Bark Pockets:** Medium - scattered.

**Pitch Streaks:** Not to exceed 1/6 the width.

**Saw Cuts:** Generally, no saw cuts shall be permitted.

**Shake & Splits:** Permitted if extending from wide faces into the thickness at an angle of 45 degrees or more from the wide face. Other restrictions are subject to special agreement.

**Skip on Face:** Hit and Miss, with a maximum of 5% of the pieces containing Hit or Miss.

**Skip on Edge:** Hit and Miss, with a maximum of 5% of the pieces containing Hit or Miss, or Heavy skip 2 feet or less in length. See NLGA Paras. 720e, 720f, and 720g unless a more restrictive requirement is specified.

**Slope of Grain:** For grading machines not evaluating slope of grain, the edge knot displacement limits the slope of grain as follows:

1/3 displacement and larger: 1 in 10

1/4 displacement and smaller: 1 in 12

*Note: Machines that measure MOE by deflection indirectly evaluate slope of grain.*

**Stain:** Medium stained sapwood. Firm heart stain.

**Timber Breaks:** Not permitted

**Torn Grain:** Medium. Spots of heavy torn grain around knot areas or equivalent.

**Warp:** Light. See NLGA Para. 752.

**Wane:** Not to exceed 1/4 inch on the wide face by 1/4 inch deep or equivalent on the edge unless a more restrictive requirement is specified.

**White Specks:** Firm. A combination of white speck and a knot in the same cross-section shall not occupy more than 1/2 the width or equivalent.

**6.3.2 MSR/MEL TENSION LAM LUMBER**

The visual requirements listed in Section 6.3.1 shall apply, except that strength reducing characteristics such as knots, knot holes, burls, abnormal grain distortion or decay, partially or wholly at the edges of wide faces, shall not occupy more of the net cross-section than listed for the characteristic MOR values or Fb designations assigned in Table 6.

*Note: This product is intended to meet the requirements of AITC 117.*

**6.4 VISUAL QUALITY LEVEL (VQL) FOR MSR AND MEL**

In addition to the visual limitations listed in Sections 6.1 or 6.2, as applicable, other strength reducing characteristics such as knots, knot holes, burls, abnormal grain distortion or decay, partially or wholly at the edges of wide faces, shall not occupy more of the net cross-

section than listed for the characteristic MOR values or Fb designations assigned in Table 6.

**TABLE 6 - STRENGTH REDUCING CHARACTERISTIC LIMITS FOR MSR, MEL, AND MSR/MEL TENSION LAM LUMBER**

Edge Displacement	Characteristic MOR Value	Fb Designation
1/2	1,890 psi & below (13.0 MPa & below)	≤ 900
1/3	1,995 psi to 3,045 psi (13.8 MPa to 21.0 MPa)	950 to 1450
1/4	3,150 psi to 4,305 psi (21.7 MPa to 29.7 MPa)	1500 to 2050
1/6	4,410 psi & over (30.4 MPa & over)	≥ 2100

**6.5 VISUAL GRADING REQUIREMENTS FOR THE UNTESTED PORTIONS OF MACHINE GRADED LUMBER**

Table 7 provides the visual requirements for the untested portions of MSR, MEL and MSR/MEL Tension Lam lumber.

**TABLE 7 - VISUAL REQUIREMENTS FOR THE UNTESTED PORTION OF MSR, MEL, AND MSR/MEL TENSION LAM LUMBER**

The ends of the lumber, not tested by a grading machine, shall be limited as follows:	
Edge Knots	As limited in Table 6
Knots Other Than Edge Knots	Equal to the largest knot in the tested portion of the piece or the edge knot permitted in the next lower <b>Characteristic MOR value</b> or <b>Fb designation category</b> , whichever is greater
Cross-Section Knots	The size or displacement of all knots in the same cross-section may not exceed the size of the permitted largest knot as described for " <b>Knots Other Than Edge Knots</b> " listed above
Slope of Grain	The limitation on the general slope of grain is based on the Fb designation assigned to the grade and shall not exceed the slope of grain listed in Table 5.
Other Strength-Reducing Characteristics	Knot holes, burls, distorted grain, or decay shall be considered the same as knots.

**6.6 ALTERNATE VISUAL QUALITY LEVELS**

**6.6.1 VISUAL GRADING REQUIREMENTS FOR ESTABLISHING ALTERNATE VISUAL QUALITY LEVELS FOR MSR OR MEL LUMBER**

Strength-reducing characteristics larger than those listed in Sections 6.1 and 6.2 may be permitted provided the additional requirements in Section 12.1.2 are



followed and ultimate tensile strength (UTS) qualification and daily quality control are performed.

In such cases, the limiting size of the strength-reducing characteristic shall be documented.

**6.6.2 ALTERNATE VISUAL QUALITY LEVELS FOR E-RATED STRUCTURAL LAM LUMBER**

A facility may elect to qualify E-Rated Structural Lam lumber to a more restrictive VQL than listed in Section 6.3.1. In such cases, strength reducing characteristics such as knots, knot holes, burls and abnormal grain distortion occurring at the edge of the wide faces shall be qualified and graded to a specific size in relation to the E-LAM grade. In addition, the limiting size of the VQL shall be documented and included on the grade stamp.

*Note 1: For example, if a VQL of 1/3 the cross-section is qualified for a 1.9E-LAM grade, then the grade stamp for this product would read 1.9E-LAM-3. The 3 signifies the denominator of the allowable VQL.*

*Note 2: The inclusion of this provision in this Standard is intended to meet the requirements of AITC 117.*

**7.0 MECHANICAL PROPERTY REQUIREMENTS**

The following requirements shall apply to the characteristic property values listed in Tables 2, 3, and 4.

*Note: Mechanical property descriptions are provided in APPENDIX III.*

**7.1 MEAN MODULUS OF ELASTICITY**

**7.1.1 MSR AND MEL GRADES**

The process mean edge bending modulus of elasticity (E) tested in accordance with Section 8.1.1 shall equal or exceed the characteristic mean modulus of elasticity value for the grade E ( $E_g$ ).

$$E \geq E_g$$

**7.1.2 E-LAM GRADES**

The process mean long span flat-wise modulus of elasticity (LS E) tested in accordance with Section 8.1.2 shall equal or exceed the characteristic mean long span modulus of elasticity value for the E-LAM grade ( $E_g$ ).

$$LSE \geq E_g$$

**7.2 MINIMUM MODULUS OF ELASTICITY**

**7.2.1 MSR GRADES**

The process lower fifth percentile for edge bending modulus of elasticity ( $E_{5th}$ ) for standard MSR grades tested in accordance with Section 8.1.1 shall equal or exceed 0.82 times the characteristic mean modulus of elasticity value for the grade E ( $E_g$ ).

$$E_{5th} \geq 0.82 \times E_g$$

**7.2.2 MEL GRADES**

The process lower fifth percentile for edge bending modulus of elasticity ( $E_{5th}$ ) for MEL grades tested in accordance with Section 8.1.1 shall equal or exceed 0.75 times the characteristic mean modulus of elasticity value for the grade E ( $E_g$ )

$$E_{5th} \geq 0.75 \times E_g$$

**7.2.3 E-LAM GRADES**

The process lower fifth percentile for long span modulus of elasticity ( $E_{5th}$ ) for E-LAM grades tested in accordance with Section 8.1.2 shall equal or exceed the minimum modulus of elasticity values listed in Table 4.

**7.3 MODULUS OF RUPTURE**

The process lower fifth percentile for edge modulus of rupture (MOR) shall equal or exceed the characteristic MOR value for the grade when subjected to a short-term test load and tested in accordance with Section 8.2.

$$MOR_{5th} \geq MOR_g$$

**7.4 ULTIMATE TENSILE STRENGTH (UTS)**

**7.4.1 MSR GRADES**

When ultimate tension strength (UTS) qualification and daily quality control is required, the process lower fifth percentile for tensile strength shall equal or exceed the characteristic UTS value for the grade when subjected to a short-term test load and tested in accordance with Section 8.3.

$$UTS_{5th} \geq UTS_g$$

**7.4.2 MEL AND MSR/MEL TENSION LAM GRADES**

Ultimate tension strength (UTS) qualification and daily quality control are required to grade stamp (mark) MEL or MSR/MEL tension lam grades.

The process lower fifth percentile for tensile strength shall equal or exceed the characteristic UTS value for the grade when subjected to a short-term test load and tested in accordance with Section 8.3.

$$UTS_{5th} \geq UTS_g$$

**7.5 SPECIFIC GRAVITY**

When qualification and daily quality control for specific gravity (SG) are required, the process mean SG shall equal or exceed the assigned characteristic SG value for the grade.

**8.0 PROPERTY EVALUATION PROCEDURES**

The test methods described in this section conform to either ASTM D198 or D2395.

**8.1 MODULUS OF ELASTICITY (E)**

**8.1.1 MSR AND MEL GRADES**

Specimens shall be tested on edge using third point loading and a span to depth ratio of 21 whenever possible. The specimen depth is the surfaced dry width as provided in Table 1.

If a span to depth ratio of 21 cannot be achieved, the span shall be the maximum span possible. The modulus of elasticity value shall be adjusted to a span to depth ratio of 21 in accordance with APPENDIX II.

Modulus of elasticity shall be determined using load and deflection data collected at load levels less than the specimen proportional limit.

Specimens shall be centred in the test span. The narrow edge, which is to be subjected to tension stress, shall be randomly selected.

**8.1.2 E-LAM GRADES**

Specimens shall be randomly tested flat-wise over a simple span using centre point loading and a span-to-depth ratio of 100, whenever possible. The specimen depth is the surfaced dry thickness as provided in Table 1.

If a span to depth ratio of 100 cannot be achieved, the span shall be the maximum span possible.

The support system for testing the grade E shall provide unrestrained support at both ends.

The device used to measure deflection shall be placed at the mid-span of the test span.

Modulus of elasticity shall be determined using load and deflection data collected at load levels less than the specimen proportional limit. Specimens shall be centred in the test span.

A pre-load of 5 lbf (24.24 N) shall be applied before the long-span E (LS E) test is performed.

Incremental loading should be sufficient to produce approximately 0.2 inch (5.1 mm) deflection in a specimen with a long-span E of 2.0 million psi (13,800 MPa). Recommended loads are listed in Table 8.

**TABLE 8 - RECOMMENDED E-LAM FLAT-WISE LS-E TEST LOADS**

Nominal Size	Test Load	
	lbf	N
2x4	10	44
2x6	10	44
2x8	15	68
2x10	15	68
2x12	20	89

**8.2 MODULUS OF RUPTURE (MOR)**

MOR shall be determined by applying a test load that will induce a maximum stress not less than the characteristic bending strength value for the grade under consideration.

Specimens shall be tested on edge using third point loading and a span to depth ratio of 21 whenever possible. The specimen depth is the surfaced dry width as provided in Table 1. If a span to depth ratio of 21 cannot be achieved the span shall be the maximum span possible.

The maximum strength-reducing characteristic as determined by visual grading shall be located in the middle third of the test span wherever possible, or as close to the middle third as possible.

For test equipment where the load is applied vertically and when there is more than 5 inches (127 mm) of lumber overhanging beyond either of the reaction supports, the calculated MOR shall be corrected for the weight of the overhanging portions. Corrections are not required provided it can be demonstrated that neglecting the correction ensures a lower MOR value. Corrections are not required where specimens are tested with the load applied in a horizontal direction.

**8.3 ULTIMATE TENSILE STRENGTH (UTS)**

UTS shall be determined by applying a test load that will induce a maximum stress not less than the characteristic UTS value for the grade under consideration.

Specimens shall be tested using a gauge length (test span) of not less than 8 feet (2.44 m) wherever the test sample lengths permit.

The maximum strength-reducing characteristic, as determined by visual grading requirements shall be positioned within the test span and, wherever possible, within a minimum of two times the nominal test specimen width away from the grips. In no case shall the strength-reducing characteristic be located partially or wholly within the grips.

The load shall not induce a rate of stress increase that will exceed 4,000 psi/minute (0.46 MPa/sec).

**8.4 SPECIFIC GRAVITY (SG)**

When qualification and quality control for SG are required for a grade, SG shall be measured using procedures such as ASTM D2395, Method A or Method B, or as outlined in Section 8.4.1. The procedures used for qualification and quality control testing shall be described in the QC Manual.

**8.4.1 FULL SPECIMEN DENSITY**

Specimen dimensions shall be measured at three locations along the specimen and averaged to ensure the accuracy of the volume.

The moisture content shall be determined for each specimen at the time of weighing. Since the SG is derived from the oven dry weight and oven dry volume of the specimen, the SG shall be adjusted to the oven dry basis using the appropriate equation from ASTM D2395, Appendix XI.

If used, moisture meter readings shall be taken at three locations along the specimen and averaged. The readings shall be taken at least 2 feet (610 mm) from either end, in the centre of the wide face.

**8.5 ENVIRONMENTAL CONDITIONS**

**8.5.1 MOISTURE CONTENT**

At the time of testing, the moisture content of the specimens shall be measured and recorded.

**8.5.2 TEMPERATURE**

At the time of testing, the temperature of the specimen and the test equipment shall be between 50° to 95°F (10° to 35°C) inclusive. For temperatures other than those specified herein, corrections for the effect of temperature on the modulus of elasticity (E) shall be made.

**9.0 GRADE STAMPING REQUIREMENTS**

For lumber produced in conformance with the requirements of this Standard, the grade stamp on each piece shall contain the product designations as noted in Table 9.

When the grade stamp on Machine Graded Lumber includes the designation “1W”, it signifies that the lumber has been visually graded to meet or exceed the optional “1W” wane limitations as described in Section 6.

**TABLE 9 - GRADE STAMPING REQUIREMENTS BY MGL PRODUCT**

DESIGNATION	MSR (Table 2a)	MSR (Table 2b)	MEL	E -Rated Structural LAM	MSR/MEL Tension LAM	EXAMPLE
Agency Identification	✓	✓	✓	✓	✓	CLSAB / ALSC Accredited Agency Identification
Facility Identification	✓	✓	✓	✓	✓	100
Species or Species Combination	✓	✓	✓	✓	✓	S-P-F
Seasoning Designation	✓	✓	✓	✓	✓	S-DRY or KD
Grading Rules	✓	✓	✓	✓	✓	NLGA
“MACHINE RATED” or “MSR”	✓	✓	-	-	✓ <sup>(3)</sup>	MSR
“MACHINE EVALUATED” or “MEL”	-	-	✓	-	✓ <sup>(3)</sup>	MEL
“E-LAM”	-	-	-	✓	✓	E-LAM
MEL Grade Code	-	-	✓	-	-	M-10
LS E Rating	-	-	-	✓	✓	2.0E-LAM
MSR Grade	✓	✓	✓	-	✓	2400Fb-2.0E or 2400Fb 2.0E or 2400Fb 2.0E
Ft Rating	Optional	✓	✓	-	✓	1925Ft
Specific Gravity <sup>(1)</sup>	Optional	Optional	Optional	Optional	Optional	0.50 SG
Alternate VQL <sup>(2)</sup>	Optional	Optional	Optional	Optional	Optional	1.9E-LAM-3
Optional 1W wane <sup>(4)</sup>	Optional	Optional	Optional	-	-	1W
<p><sup>(1)</sup> When the value is higher than the assigned value for species or grade.</p> <p><sup>(2)</sup> The maximum VQL if the requirements of Section 6.6 are met.</p> <p><sup>(3)</sup> Either MSR or MEL</p> <p><sup>(4)</sup> When 1W wane limitations are met</p>						
<p><b>Note:</b> When “Optional” items are marked on the grade stamp, the facility shall follow the additional quality control procedures as specified in this Standard.</p>						

## PART B - QUALIFICATION AND QUALITY CONTROL REQUIREMENTS

### 10.0 EQUIPMENT

The facility's grading machine and test equipment shall meet the following requirements:

#### 10.1 GRADING MACHINE

The grading machine shall be of a make and model for which Agency application to the Canadian Lumber Standards Accreditation Board (CLSAB) and the American Lumber Standard Committee (ALSC) has been made and approval has been granted.

#### 10.2 QUALITY CONTROL TEST EQUIPMENT

The test equipment shall be capable of accurately measuring the mechanical properties described in Part A of this Standard. An independent calibration laboratory shall calibrate the test equipment.

*Note: The use of load and deflection measuring devices that are accurate to within 1% of the actual measurement is preferred.*

##### 10.2.1 MOE TEST EQUIPMENT ACCURACY

The test span and the location of the load points shall be capable of being set to within  $\pm 1/16$  inch (1.6 mm). The device used to measure deflection shall be capable of measuring to the nearest 0.001 inch (0.025 mm).

The deflection and load measuring devices shall be accurate to within  $\pm 2\%$  of the actual measurement.

The load shall be applied through a crosshead. The rate of crosshead movement shall not exceed 5 inches/minute (2.12 mm/second) during specimen testing.

##### 10.2.2 MOR TEST EQUIPMENT

The test span and location of the load points shall be capable of being set to within  $\pm 1/16$  inch (1 mm).

The load-measuring device shall be accurate to within  $\pm 2\%$  of the actual load.

The load shall be applied through a crosshead. The rate of the crosshead movement shall not exceed 5 inches/minute (2.12 mm/second) during specimen testing.

##### 10.2.3 UTS TEST EQUIPMENT

The test span shall be set to within  $\pm 3$  inches (76.2 mm) of the specified test span.

The load-measuring device shall be accurate to within  $\pm 2\%$  of the actual load.

The rate of load application shall not exceed 4,000 psi/minute (0.46 MPa/second) during specimen testing.

##### 10.2.4 SG TEST EQUIPMENT

The specimen dimensions shall be measured to within  $\pm 0.3\%$  of the actual thickness, width, and length. The specimen weight shall be measured to within  $\pm 0.2\%$  of the actual full weight or  $\pm 0.1\%$  of the actual half-weight.

##### 10.2.5 E-LAM LUMBER TEST EQUIPMENT

The device used to measure deflection shall be capable of measuring to the nearest 0.001 inch (0.025 mm).

The E-LAM test equipment shall be capable of testing at a span to depth ratio of 100.

*Note: The support system should be capable of accommodating twisted lumber.*

Weights for pre-load and deflection measurements shall be accurate to within  $\pm 0.05$  lbf (0.22 N). The weight shall be chosen to provide a precision of  $\pm 1\%$  or better at an E value of 2.0 million psi (13,789 MPa).

*Note: Dynamic E equipment (i.e., E-computer) can be used for daily quality control in lieu of the load/deflection method described in Section 8.1.2 provided it can be demonstrated that the results of the tests using the dynamic E equipment are consistent with results using the load/deflection method described above.*

### 11.0 QUALITY CONTROL MANUAL

#### 11.1 GENERAL

The Quality Control (QC) Manual is a document outlining the requirements for maintaining quality control in the manufacturing facility.

*Note: See APPENDIX VIII for a general commentary on the contents of a QC Manual.*

All product quality control processes outlined in the QC Manual shall comply with the requirements of this Standard.

#### 11.2 PREPARATION, REVISION AND APPROVAL

Each facility shall:

- a) Prepare a QC Manual in compliance with this Standard and submit the QC Manual to the Agency for approval,
- b) Regularly review and update its QC Manual to reflect current production practices and procedures, quality control policies, and quality control program procedures and resubmit to the Agency, and
- c) Upon approval, implement the new or updated program in accordance with the QC Manual.

The Agency shall approve the QC Manual at the time of qualification. Qualification shall apply only to the manufacturing, quality control procedures and limits set forth in the QC Manual.

The Agency shall be notified in advance of any changes in the QC Manual that may affect product quality.

### 11.3 CONTENTS

#### 11.3.1 AGENCY

The QC Manual shall identify the CLSAB and ALSC accredited Agency and include a summary of the following:

- a) That the Agency machine graded lumber certification and quality control procedures comply with the CLSAB Regulations and the ALSC Machine Graded Lumber Policy,
- b) That the responsibility for the certification and quality control procedures is that of the Agency, and
- c) That the CLSAB and the ALSC shall monitor whether certification and quality control procedures are being carried out by the Agency.

#### 11.3.2 GENERAL FACILITY ADMINISTRATION

The QC Manual shall:

- a) Define facility management policies, objectives and responsibilities for quality control, including the responsibility for each division within a multi-division organization,
- b) Define the responsibility and authority for those managing and performing the quality control work and of those that are confirming conformance to quality control requirements.

*Note: The facility management relationships may be shown on organization charts.*

- c) Identify the Supervisor who shall report regularly to management at a level to ensure that quality control requirements are not subordinated to manufacturing or sales. The QC Manual shall define the Supervisor's authority to resolve quality matters, and
- d) Define the responsibility and authority of personnel responsible for quality control and their organizational freedom to:
  - i) Identify and record non-conformance to quality,
  - ii) Recommend or provide solutions through designated positions in the organization,
  - iii) Confirm implementation of solutions, and
  - iv) Oversee further processing of a non-conforming item(s) until the deficiency or unsatisfactory condition has been corrected.

#### 11.3.3 QUALITY CONTROL PERSONNEL

The QC Manual shall outline the responsibilities of the quality control personnel.

Persons responsible for quality control shall possess and demonstrate to the satisfaction of the Agency that they have adequate knowledge of the manufacturing process which shall include:

- a) Inspection and test procedures used to monitor the production process,
- b) Operation and calibration of the recording and test equipment used, and
- c) Maintenance and interpretation of the quality control records.

In addition, the quality control personnel shall be responsible for carrying out and maintaining records of various inspections and test procedures detailed in the QC Manual.

The quality control personnel shall formally advise the facility management of circumstances resulting from the inspections and test procedures that indicate corrective action may be necessary in the production process.

#### 11.3.4 QUALITY CONTROL PROCEDURES

The QC Manual shall include detailed descriptions specifying how each of the following procedures is to be performed and controlled:

- a) Grading machine operation and calibration, including a list of major maintenance activities that might affect the ability of the grading machine to assess the indicating property,
- b) Test equipment operation including calibration and spot-check procedures,
- c) Quality control sampling, testing and analysis,
- d) Documentation and record keeping,
- e) Identification and traceability,
- f) Non-conformances, and
- g) Corrective action.

### 12.0 QUALIFICATION AND SAMPLING REQUIREMENTS

#### 12.1 INITIAL QUALIFICATION

##### 12.1.1 GENERAL

A facility requesting initial qualification shall provide the Agency with evidence that all the requirements of **Part A** have been met. Upon receipt of the request, the Agency supervisor will visit the facility to determine that:

- a) The facility is capable of operating within the requirements of its QC Manual,
- b) The facility personnel possess ability to undertake the requirements described in Section 11.3.4, and



- c) The calibration of the grading machine and the test equipment conforms to the requirements of the QC Manual.

**12.1.2 QUALIFICATION REQUIREMENTS FOR AN ALTERNATE VQL**

- a) To qualify an alternate VQL with characteristics that are larger than those listed in Section 6, a maximum VQL shall be specified that has the potential of being qualified. Prior to selecting the qualification samples, 6 specimens, containing the maximum VQL to be qualified, shall be randomly selected.

The specimens shall be tested with the maximum VQL positioned in the test span. Each of the 6 specimens shall satisfy the required tension test load for the grade under consideration.

- b) When an alternate VQL is qualified, the qualification sample shall include the maximum characteristic as it randomly occurs.
- c) The alternate VQL shall be re-qualified whenever qualification testing is required for the grade.

**12.1.3 QUALIFIED ITEM(S)**

Each item shall be qualified before issuing grade stamps. Items shall be qualified for the item combination in which they will be produced.

*Note: If multi-item combinations are qualified, dropping an item does not require a requalification provided grading machine boundary settings remain the same.*

**12.2 QUALIFICATION SAMPLING**

The Agency Supervisor shall select a minimum of 53 machine-graded specimens. The specimens shall be representative of the item to be qualified. Each specimen shall meet the visual requirements of Section 6 for the grade being qualified.

*Note: At the discretion of the Agency supervisor, specimens rejected from a higher grade may be permitted in the 53-specimen sample provided the supervisor confirms that the specimens have been rejected due to visual override.*

When ultimate tensile strength (UTS) qualification is required, an additional 53 machine-graded specimens shall be selected. These samples shall meet the visual requirements of Section 6 for the grade being qualified.

The Agency Supervisor shall confirm the visual grade of all specimens in this sample rejected from a higher grade due to visual override.

A maximum of 3 additional samples to increase the total of specimens to 78, 102 or 125 may be selected to qualify the minimum modulus of elasticity, modulus of rupture (MOR) and/or tensile strength.

When MSR/MEL tension laminations lumber is to be qualified, long-span MOE shall be qualified using either the 53-specimen sample selected for the edge-wise E test, or the 53-specimen sample selected for the UTS tests (if applicable), or a separate 53-specimen sample may be generated.

The long-span E testing shall be performed before any MOR or UTS tests are conducted.

When specific gravity is to be qualified, the specific gravity shall be determined for each specimen from the 53-specimen bending samples prior to conducting the MOR test.

*Note: The minimum sample sizes and decision rules are based on non-parametric estimates of the lower tolerance limit for the population 5<sup>th</sup> percentile at a 75% confidence level.*

**12.3 QUALIFICATION TESTING**

Table 10 designates the properties for which qualification and daily quality control are required for each category of Machine Graded Lumber.

All testing shall be performed in accordance with the procedures described in Section 8.

**12.4 ANALYSIS OF QUALIFICATION TESTS**

Results of all the required tests shall determine whether grade stamps will be issued for each item qualified.

For strength evaluations, specimens that satisfy the test load without fracture or with only partial failure shall be deemed to meet the test requirements. The test load shall be recorded.

If a specimen fails before the test load has been achieved, the load at failure shall be recorded.

An item shall be considered qualified when the following requirements have been met:

- a) The mean modulus of elasticity of the 53-specimen sample, equals or exceeds  $E_g$  minus 0.258 times the sample standard deviation when edge E or long-span E is qualified, and
- b) The minimum modulus of elasticity:
  - i) for MSR grades (Table 2), not more than 1 of the specimens have a modulus of elasticity value less than 82% of  $E_g$ , or
  - ii) for MEL grades (Table 3), not more than 1 of the specimens have a modulus of elasticity value less than 75% of  $E_g$ , or
  - iii) for E-rated structural lam grades, not more than 1 of the specimens have a long-span modulus of elasticity value less than the minimum E values listed in Table 4, or
  - iv) for MSR/MEL tension lam grades not more than 1 of the specimens have a long-span modulus of elasticity value less than the minimum E values listed in Table 4 and not more than 1 of the specimens have an edge

modulus of elasticity value less than 82% of  $E_g$  listed in Table 2 or 3, as applicable, and

- c) When MOR evaluation is required, not more than 1 of the specimens have a modulus of rupture less than the characteristic MOR value,
- d) When tensile strength evaluation is required, not more than 1 of the specimens have a tensile strength less than the characteristic UTS value, and
- e) When specific gravity is to be qualified, the mean specific gravity of the 53-specimen sample equals or exceeds 0.98 times the grade characteristic SG.

When the additional sampling procedure referred to in Section 12.2 is used to qualify for minimum modulus of elasticity, modulus of rupture or, when required, tensile strength, the number of specimens in Clauses b), c) and d) above shall not exceed 2 in a 78-specimen sample, 3 in a 102-specimen sample or 4 in a 125-specimen sample.

When the test results do not meet the above requirements, the facility may elect to qualify at a lower grade of the same visual quality level.

Alternatively, adjustments to the grading machine boundary settings may be made. New samples shall be selected and tested until the above requirements are satisfied.

**12.5 INCREASED (DOUBLE) SAMPLING FOLLOWING QUALIFICATION**

Immediately following qualification, increased (double) sampling shall be performed on the items qualified. Test results shall satisfy the quality control requirements of this Standard.

*Note: See definition of increased (double) sampling under Section 2.1 – Sampling Frequencies.*

**TABLE 10 - PROPERTY TEST REQUIREMENTS FOR QUALIFICATION AND DAILY QUALITY CONTROL BY MGL PRODUCT**

Property	MSR (Table 2a)	MSR (Table 2b)	MEL	E-Rated Structural LAM	MSR/MEL Tension LAM
Average Edge E	✓	✓	✓	-	✓
Min Edge E	✓	✓	✓	-	✓
Average Long-span E	-	-	-	✓	✓
Min Long-span E	-	-	-	✓	✓
Bending Strength (MOR)	✓	✓	✓	-	✓
Tensile Strength (UTS)	Optional	✓	✓	-	✓
Alternate VQL	Optional	Optional	Optional	Optional	Optional
Specific Gravity	Optional	Optional	Optional	Optional	Optional

*Note: When "Optional" items are marked on the grade stamp, the facility shall follow the additional quality control procedures specified in this Standard.*

**12.6 SUBSEQUENT QUALIFICATION**

Separate qualification tests are required for each new item for which grade stamps are desired. When a facility qualified to produce a given item or item combination wishes to add a new item, the following tests shall be performed:

- a) Qualification tests on the new item,
- b) Intensive sampling on the adjacent lower item of the existing combination, and
- c) Increased (double) sampling, following qualification of the new item, on both the new item and the adjacent lower item of the existing combination.

*Note: See definition of intensive sampling and increased (double) sampling under Section 2.1 – Sampling Frequencies.*

For Clauses b) and c) above, test results shall meet the quality control requirements of this Standard.

Initial re-qualification is required at an existing qualified facility if any of the following scenarios occur:

- a) Replacement of the grading machine,
- b) Pulling a higher design item(s) sort from the lumber flow before the grading machine that was not in effect at the time of the original initial qualification, or
- c) Any other situation which, in the Agency’s judgement, may result in an adverse impact to the MGL product quality.

**12.7 MACHINE ADJUSTMENT (FINE-TUNING) FOLLOWING QUALIFICATION**

Upon qualification of an item, the grade boundary settings of the grading machine may be adjusted. Further procedures shall be performed as follows:

- a) The Agency shall be notified when adjustments consist of lowering the settings.

- b) Intensive sampling shall be performed on the item for which the boundary settings were lowered and for the adjacent lower grade item. Test results shall satisfy the quality control requirements of this Standard.
- c) When adjustments consist of lowering the settings by more than 3%, singular or cumulatively within any three consecutive production shifts, then increased (double) sampling shall be performed on the item for which the boundary settings were lowered, and the adjacent lower grade item being selected in combination.

## 12.8 NON-PRODUCTION OF QUALIFIED GRADES

When a facility does not produce a particular MSR, MEL, or E-LAM item(s) for a period exceeding 1 year, subsequent production of that item shall only be permitted after intensive sampling is performed on the item. The test results shall satisfy the quality control requirements of this Standard.

When a qualified facility does not produce any MSR, MEL, or E-LAM lumber for a period exceeding one year, item(s) in the start-up grade combination shall be subject to qualification testing and increased (double) sampling, and all other grade combinations shall be subject to intensive and increased (double) sampling. The Agency shall be satisfied that the requirements of Section 12.1.1 are met prior to start-up of production.

## 12.9 NOTIFICATION REQUIREMENTS FOR DISCONTINUANCE OF QUALITY CONTROL PROCEDURES

When an item that has been qualified under the procedures for quality control of tensile strength, specific gravity or alternate VQL's, discontinuance of the procedure requires written notification from the facility to the Agency at least one week prior to the action being taken.

## 12.10 GRADING MACHINE MAJOR MAINTENANCE

Agency notification is required when there is major maintenance carried out on the grading machine.

At a minimum, intensive sampling shall be performed on the first item being produced after major maintenance, having regards to the nature of the maintenance. The test results shall meet the quality control requirements of this Standard.

*Note: See definition of major maintenance in Section 2.1.*

## 13.0 EQUIPMENT CALIBRATION

Records of all calibration and spot-check verifications shall be maintained for at least 6 years.

## 13.1 GRADING MACHINE

A grading machine shall be calibrated in accordance with the procedures set forth in the QC Manual.

Calibration checks shall be performed as follows:

- a) At the start-up of each production shift,
- b) Approximately every 4 hours, but not exceeding 5 hours of grading machine operation, or as prescribed by the grading machine manufacturer thereafter,
- c) After any adjustment to the grading machine, and
- d) After any maintenance to the grading machine.

## 13.2 TEST EQUIPMENT

An independent calibration laboratory acceptable to CLSAB shall calibrate the test equipment prior to initial qualification and once a year thereafter. Any extension to the 12-month requirement shall be authorized in writing by the independent calibration laboratory. Under no circumstances shall the extension exceed 1 month.

It is the responsibility of the facility to maintain the operating condition of its test equipment in accordance with requirements set forth in their Quality Control Manual, Equipment Operation Manual, and this Standard.

The test equipment shall be spot-checked in accordance with procedures set forth in the Quality Control Manual and with the applicable sections in ASTM E4, ASTM E83 and/or other applicable nationally recognized standards.

*Note: Along with the listed standards, there are other acceptable test standards and procedures for calibrating measuring devices and equipment. These standards must be nationally recognized and acceptable to CLSAB.*

Spot-checks shall be performed at a frequency level listed in Table 11 and whenever there is reason to suspect the equipment may be out of calibration or damaged.

The Agency shall be notified immediately if damage and/or repair to the test equipment or a spot-check device has occurred, which may result in a re-calibration of the test equipment or spot-check devices by an independent calibration laboratory.

The calibration report and certificates from the independent calibration laboratory shall comply with the reporting requirements outlined in ASTM E4, ASTM E83, and/or other applicable nationally recognized standards.



TABLE 11 - TEST EQUIPMENT SPOT-CHECK FREQUENCY

Equipment	Minimum Spot-Check Frequency
Bending Proof Loader	At least once a shift with a proof bar and once a week with a proof ring or load cell.
Tension Tester	At least once a week
Other Test Equipment	As per manufacturer's specifications, the QC Manual, or this Standard, whichever period is more frequent.

**13.2.1 INDEPENDENT CALIBRATION LABORATORY REPORTING REQUIREMENTS**

The report of the independent calibration laboratory shall include at least:

- a) Results of the calibration of the sensors of the equipment following applicable sections of ASTM E4 and ASTM E83,
- b) Description of the method of verification including details of the preloading,
- c) Indication if the sensitivity or point of calibration of the test equipment was changed or not,
- d) Information on the Reference calibration devices used by the laboratory including the due date of calibration,
- e) The average target and tolerance values to be used,
- f) A statement that the test equipment is in satisfactory working condition,
- g) Temperature near the test equipment at time of the calibration,
- h) Whether a mill facility operator was present to confirm values, and
- i) Date and location of the calibration.

A copy of the final calibration report shall be forwarded to the Agency.

**13.3 CALIBRATION DEVICES**

The calibration devices used by the independent calibration laboratory shall meet the applicable requirements of ASTM E74 for force-measuring devices, ASTM E83 for displacement devices and/or other applicable nationally recognized standards acceptable to CLSAB.

**14.0 QUALITY CONTROL REQUIREMENTS**

**14.1 QUALITY CONTROL PROCEDURES**

The quality control procedures described herein are intended to detect non-conformance. All properties required to be qualified under Section 12.0 must be quality controlled.

This Standard utilizes the Cumulative Sum (CUSUM) control chart method as one method of maintaining statistical control of a process.

*Note: CUSUM parameters are shown in APPENDICES IV and IX.*

Quality control procedures other than those described (CUSUM) may be used in conjunction with this Standard, provided they assure that the requirements described in Part A have been met.

*Note: The choice of a given quality control method implies a commitment not only to the data analysis procedures but also to the sampling procedures (sample size as well as sampling frequency).*

The quality control procedures used by a facility shall be fully documented in the QC Manual.

**14.2 QUALITY CONTROL SAMPLING**

**14.2.1 SAMPLING METHOD**

The Agency shall approve the sampling method. Specimens shall be randomly sampled from grade stamped production.

*Note: The intent is to collect a sample that is representative of production over the work shift. This can be achieved by obtaining QC test specimens at approximate equal time intervals throughout the production shift.*

**14.2.2 SAMPLING FREQUENCY**

A minimum of one 5-specimen sample for each period of 4 hours or less of production shall be selected and tested for modulus of elasticity (MOE) and modulus of rupture (MOR) for MSR and MEL grades, and long-span E (LS E) for E-LAM grades.

When tensile strength evaluation is required, an additional 5-specimen sample shall be obtained for each period of 4 hours or less.

When specific gravity evaluation is required, the specimen density shall be determined for each specimen in the sample selected for MOE and MOR evaluation.

*Note: See APPENDIX VI for commentary on Quality Control sampling frequency.*

**14.3 QUALITY CONTROL TESTING**

Testing for modulus of elasticity, modulus of rupture and, as required, tensile strength and specific gravity, shall be performed in accordance with the procedures described in Section 8.0.

*Note: There is no requirement to immediately test the QC sample, but it is good practice to do so. If samples are accumulated, the facility must institute procedures to maintain specimen moisture content until testing.*

Shipment of production is permitted only after testing of the QC sample representative of production is completed and the “**IN-CONTROL**” state is verified. If an “**OUT-OF-CONTROL**” situation is encountered, all subsequent production shall be held until the procedures in Section 14.4.2 are performed.

#### 14.4 ANALYSIS OF QUALITY CONTROL TESTS

Test results shall be entered on Agency approved control forms. The control forms shall be designed so that the properties qualified under Section 12.4 are recorded and “**IN-CONTROL**” and “**OUT-OF-CONTROL**” situations shall be readily detectable.

##### 14.4.1 IN-CONTROL

When all the process properties referred to above remain “**IN-CONTROL**”, the item from which the quality control sample was drawn shall be deemed to be compliant with the mechanical property requirements of this Standard.

##### 14.4.2 OUT-OF-CONTROL

The requirements of this section relate to the conditions described in the APPENDIX V flowcharts.

When any of the process properties described in Section 14.4.1 goes **OUT-OF-CONTROL**, the item production from which the quality control sample was drawn shall be held pending results of the following tests:

- a) Visual grade,
- b) Moisture content,
- c) Calibration of the grading machine,
- d) Grade boundary settings, and
- e) Spot-check of the test equipment.

The results of the tests shall determine the course of action that shall be taken in the following manner:

##### **RESULT A**

When the accuracy of the visual grade, moisture content and all equipment calibrations/spot-checks are confirmed, intensive sampling shall be taken from continued production.

When test results indicate that the process is back “**IN-CONTROL**”, the held item shall be deemed to comply with the mechanical property requirements of this Standard, and the production of MSR, MEL or E-LAM lumber may resume.

When the test results continue to show that the process is still “**OUT-OF-CONTROL**”, the facility shall proceed to either **ACTION 1** or **ACTION 2**, as applicable.

##### **RESULT B**

When the accuracy of the visual grade or the moisture content is found in error and all equipment

calibrations/spot-checks have been confirmed, the facility has the option of either immediately re-grading the held item for visual grade and/or moisture content or performing intensive sampling on the held item.

When the intensive sampling option is selected, the item shall be deemed to comply with the mechanical property requirements of this Standard when the “**IN-CONTROL**” requirements have been regained. When the test results continue to show that the process is still “**OUT-OF-CONTROL**”, the item shall be re-graded for visual grade and/or moisture content.

Intensive sampling shall be performed on the residual of the re-graded MSR, MEL or E-LAM lumber item. When the test results confirm that the “**IN-CONTROL**” requirements have been regained, the re-graded item shall be deemed to comply with the mechanical property requirements of this Standard. When the test results continue to show that the process is still “**OUT-OF-CONTROL**”, the facility shall go to either **ACTION 1** or **ACTION 2**, as applicable.

##### **RESULT C**

When the grading machine calibration or test equipment spot-check is found in error, corrective action shall be taken to correct the condition prior to further machine grading or testing being performed.

When only the test equipment spot-check is found in error, an additional 5-specimen sample shall be selected and tested from the held item.

When the grading machine calibration is found in error, intensive sampling shall be performed from the continued production.

When the test results confirm that the “**IN-CONTROL**” requirements have been regained, the production of MSR, MEL or E-LAM lumber may resume, and the held production shall be evaluated in accordance with **ACTION 3**.

When the test results continue to show that the process is still “**OUT-OF-CONTROL**”, the facility shall go to either **ACTION 1** or **ACTION 2**, as applicable.

##### **ACTION 1**

When grade boundary settings are changed by 3% or less, intensive sampling shall be performed from continued production.

When the test results confirm that the “**IN-CONTROL**” requirements have been regained, MSR, MEL or E-LAM production may resume, and the held item shall be evaluated in accordance with **ACTION 3** if the equipment calibration/spot-check needed adjustment.

When the test results continue to show that the process is still “**OUT-OF-CONTROL**”, the facility shall go to **ACTION 2**.

### **ACTION 2**

When grade boundary settings are changed by more than 3% the held item shall be deemed to be in non-compliance with the requirements of this Standard and all grade stamps shall be obliterated from the MSR, MEL or E-LAM lumber.

Only after appropriate action has been taken to correct the process and intensive sampling test results confirm that the “**IN-CONTROL**” requirements have been regained may the process be deemed to be back “**IN-CONTROL**”. Increased (double) sampling shall then be performed on continued production of the item.

### **ACTION 3**

The quality of the held item shall be evaluated as follows:

- a) When the grading machine calibration is adjusted by 2% or less or the test equipment spot-check required adjustment, the held item shall be considered to comply with the mechanical property requirements of this Standard, or
- b) When the grading machine calibration is adjusted by more than 2%, intensive sampling shall be performed on the held item.

When the test results confirm that the “**IN-CONTROL**” requirements have been regained, the held item shall be deemed to comply with the mechanical property requirements of this Standard.

When the test results confirm an “**OUT-OF-CONTROL**” process, the held item shall be deemed to be in non-compliance with the requirements of this Standard and all grade stamps shall be obliterated from the MSR, MEL or E-LAM lumber.

## **14.5 IDENTIFICATION AND TRACEABILITY**

Each package of MSR, MEL or E-LAM lumber leaving the facility production line shall be identified with the time and date it left the production line.

*Note: This labelling allows for traceability of an item in the event that further testing is required, or an “**OUT-OF-CONTROL**” condition is encountered.*

## **14.6 QUALITY CONTROL RECORDS**

Facility quality control records shall include:

- a) Grading machine calibration and maintenance data (if applicable),
- b) Test equipment calibration, spot-check and maintenance data,
- c) Grade boundary settings and subsequent changes to the grade level boundary settings,
- d) Quality control tests,

- e) All MSR, MEL and E-LAM production stoppages due to quality control requirements and a report of the corrective actions taken, and
- f) A record of the temperature near the test equipment at the time of the spot checks.

Separate records shall be maintained for each item produced. In some instances, a given item may be run individually or in combination with other items. In either case, one CUSUM record shall be maintained if an item is run individually and another CUSUM record shall be maintained when an item is run in combination with another item(s).

All records shall include the date when performed and shall be retained for at least 6 years.

These records shall be made available to the Agency upon request.

## **15.0 RE-INSPECTION PROVISIONS**

### **15.1 GENERAL**

Response to complaints on MSR lumber, MEL or E-LAM involving visual grade, size, moisture content, tally or assigned design values, shall be based on the applicable requirements within this section of the Standard, and by the requirements set forth in NLGA Para. 400.

*Note: For E-LAM lumber, moisture content, surfacing and wane provisions may be subject to special agreement between the buyer and seller. Specifications for these provisions should be defined in the contract prior to the purchasing of E-LAM lumber.*

Sample selection and testing shall be performed by the Agency whose logo appears on the lumber (or by an independent accredited testing organisation approved by the original Grading Agency).

Only certified test equipment calibrated to a national standard and using a process mutually agreed upon by the Agency, the seller, and the buyer shall be used.

The sample sizes and conformance requirements are provided in Table 12 for MSR Lumber, E-LAM and MSR tension lam lumber, and in Table 13 for MEL and MEL tension lam lumber.

In cases of complaints pertaining to conformance to assigned design values, an 80-specimen sample representing the item shall be randomly selected.

The properties, for which conformance are required shall include: the mean flexural stiffness and the minimum flexural stiffness. Testing and reporting of the modulus of elasticity for computing flexural stiffness shall meet the requirements of APPENDIX I.

Testing shall be performed in accordance with Section 8.

Since a change in the moment of inertia (I) due to shrinkage and swelling of lumber is largely offset by changes in modulus of elasticity (E), changes to flexural stiffness (EI), in the range of 12 to 18 percent moisture content are insignificant for the purposes of re-inspection.

When tests show that an item is in non-conformance, all re-inspection and testing costs shall be borne by the seller and the item shall become the property of the seller. If tests show that the item is in conformance, these costs shall be borne by the buyer, and the item shall be the property of the buyer.

When a complaint involves more than one item in a shipment, re-inspection and testing costs shall be borne proportionally to the volume of non-conforming items in the entire shipment.

The original grade stamp shall be obliterated on any non-conforming lumber.

**TABLE 13 - CONFORMANCE CRITERIA FOR MEL & MEL TENSION LAM RE-INSPECTION**

PROPERTY	SAMPLE SIZE	CONFORMANCE CRITERIA
Mean E (E or LS E, as applicable)	80 Specimens	The mean value of the sample E shall equal or exceed 0.97 times the assigned grade E value.
Min E		<p><b>For MEL:</b> Not more than 6 specimens have a grade E value less than 0.75 times the assigned grade E value.</p> <p><b>For MEL Tension Lam:</b> Not more than 6 specimens have a long-span E of less than the minimum MOE values listed in Table 4.</p>

**TABLE 12 - CONFORMANCE CRITERIA FOR MSR, E-LAM AND MSR TENSION LAM LUMBER RE-INSPECTION**

PROPERTY	SAMPLE SIZE	CONFORMANCE CRITERIA
Mean E (E or LS E, as applicable)	80 Specimens	The mean value of the sample E shall equal or exceed 0.97 times the assigned grade E value.
Min E		<p><b>For MSR:</b> Not more than 6 specimens have an E value less than 0.82 times the assigned grade E value.</p> <p><b>For E-LAM &amp; MSR Tension Lam:</b> Not more than 6 specimens have a long-span E of less than the minimum MOE values listed in Table 4.</p>

**PART C – EUROPEAN UNION EXPORT REQUIREMENTS FOR MACHINE GRADED LUMBER**

**16.0 EU EXPORT REQUIREMENTS FOR MGL**

Machine Graded Lumber (MGL) graded in accordance with Parts A and B of this Standard shall meet the additional requirements referenced below to comply with European (CEN) Standards for the application of a CE designation to the lumber.

The following sections detail the additional requirements as applied by CLSAB.

**16.1 REFERENCED PUBLICATIONS**

- EN 336** Structural timber – Sizes, permissible deviations
- EN 338** Structural timber – Strength classes
- EN 384** Structural timber – Determination of characteristic values of mechanical properties and density
- EN 408** Timber structures – Structural timber and glued laminated timber – Determination of some physical and mechanical properties

**EN 14081-1** Timber structures – Strength graded structural timber with rectangular cross section - Part 1: General requirements

**EN 14081-2** Timber structures – Strength graded structural timber with rectangular cross section - Part 2: Machine grading; additional requirements for type testing

**EN 14081-3** Timber structures – Strength graded structural timber with rectangular cross section - Part 3: Machine grading; additional requirements for factory production control

**16.2 VISUAL GRADING REQUIREMENTS**

All visual grading requirements listed in Section 6 apply except for those specific sections listed in this Part that exceed the NLGA minimum requirements.

**16.2.1 SIZE TOLERANCES**

In EN 336, provisions are made for dimensional deviation within two tolerance classes. These tolerances are provided in Table 14.

**TABLE 14 - CEN SIZE TOLERANCES**

Thickness & Width	Tolerance Class 1	Tolerance Class 2
≤ 100 mm	(+3 and -1) mm	(+1 and -1) mm
>100 mm	(+4 and -2) mm	(+1.5 and -1.5) mm
<i>Note: The Tolerance Class to which the lumber has been produced should be indicated on the contract documents. NLGA provisions shall apply to dressed lumber.</i>		

**16.2.2 MEASUREMENT**

Measurement of cross-section deviations for lumber ordered to Tolerance Class 1 or 2 are determined at the reference moisture content of 20%.

**Note 1:** The term “Target Size” may appear on order contracts.

**Note 2:** For reference, the EN 336, Clause 3.1 definition for “target size” is: “Size used to indicate the size desired (at 20% moisture content), and to which the deviations, which would ideally be zero are to be related.”

**16.2.3 BIOLOGICAL CHARACTERISTICS**

No active insect infestation permitted. Wood wasp holes are not permitted.

**16.2.4 UNSOUND WOOD AND DOTE**

Unsound wood and dote (excluding white specks) are not permitted in C16 and higher strength classes.

**16.2.5 WANE**

The allowable wane permitted shall not be greater than 1/3 of the thickness and/or width of the piece.

**Note:** For reference, EN 14081-1, Annex A.2.1 states “The maximum wane permitted shall not reduce the edge and face dimensions to less than 2/3 of the basic dimensions of the piece.”

The limits on wane are absolute. The following additional restrictions shall apply:

- No provisions for averaging wane over the length of the piece,
- No allowance for wane dips, and
- Manufactured holes are treated as equivalent to wane (not equivalent to knot holes).

**16.2.6 WARP (DISTORTION)**

The maximum limits for warp (distortion) are provided in Table 15. The maximum distortion is measured over 2 m of length.

**TABLE 15 - CEN WARP (DISTORTION) LIMITS**

Warp Type	Maximum permissible distortion for each Strength Class	
	C18 and below	Above C18
<b>Bow</b>	20 mm	10 mm
<b>Crook (Spring)</b>	12 mm	8 mm
<b>Twist</b>	2 mm per 25 mm width	1 mm per 25 mm width
<b>Cup</b>	As per NLGA Grade Rules for the MGL grade	

**16.2.7 SHAKE, CHECKS AND SPLITS (FISSURES)**

Fissure length limits are specified in Table 16.

**TABLE 16 - CEN PERMITTED LENGTHS OF SHAKE, CHECKS, AND SPLITS (FISSURES)**

Fissure depth	C18 and below	Above C18
Less than ½ the thickness	Ignored for all strength classes	
<u>Not penetrating through the thickness</u>	No greater than 1.5 m or ½ the length of the piece, whichever is the lesser	No greater than 1 m or ¼ the length of the piece, whichever is the lesser
<u>Penetrating through the thickness</u>	No greater than 1 m or ¼ the length of the piece, whichever is the lesser. If at the ends, a length not greater than 2 times the width of the piece	Only permitted at the ends with a length not greater than the width of the piece

**16.2.8 ABNORMAL DEFECTS**

Where the reduction in strength caused by the abnormal defect is obviously less than caused by other defects permitted, the piece may be accepted provided the defect is of a type that will not increase after conversion and drying.

**16.3 GRADE STAMP REQUIREMENTS**

In addition to the grade-stamping requirements of Section 9, structural lumber graded in accordance with EN 14081-1 shall also include the following information on the grade stamp:

- Identification number of the Notified Body.
- The letter “M” to signify machine graded.
- CEN Strength class (e.g., C24). <sup>(1)</sup>
- Seasoning state “**DRY GRADED**” or “**KD**”. <sup>(2)</sup>
- If applicable, “**HT**” to indicate phytosanitary heat treatment.
- The stylized “**CE**” mark.

<sup>(1)</sup> **Note:** See Table 17 for the MGL grade and CEN strength class assignment matrix.

<sup>(2)</sup> **Note:** The term “**KD**” is acceptable if cross-referenced to “**DRY GRADED**” in the Declaration of Performance (DOP) that the manufacturer supplies with the product.

**Note:** This “dual” grade stamp allows for the acceptance of MGL in both the North American and EU markets.

**FIGURE 1 - EXAMPLES OF TYPICAL NORTH AMERICAN / EU GRADE STAMPS FOR MACHINE GRADED LUMBER**

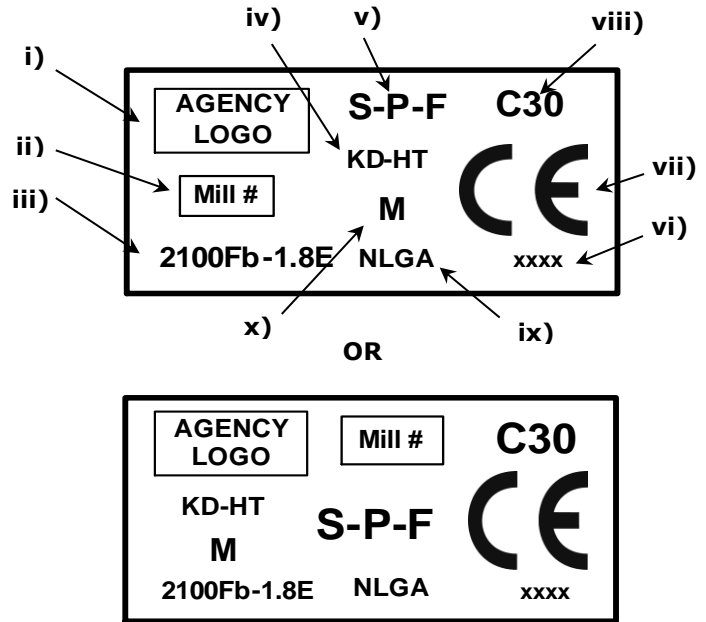

Where:

- i) Agency logo (CLSAB/ALSC accredited Agency)
- ii) Mill number
- iii) MSR Grade
- iv) Seasoning and Phytosanitary State
- v) Species or Species Combination
- vi) Identification number of the Notified Body
- vii) CE Logo
- viii) CEN Strength Class
- ix) Grading rule
- x) Letter “M” to signify that the lumber is machine graded

**16.4 MGL GRADE AND STRENGTH CLASS ASSIGNMENTS**

Table 17 identifies the MGL grades which satisfy the requirements for EN 338 strength classes for lumber graded in accordance with this Standard.

Strength class assignments are only applicable to MGL from the S-P-F, D Fir-L (N), and Hem-Fir (N) species groups.



TABLE 17 - CEN STRENGTH CLASS ASSIGNMENTS

Strength Class	MGL Grade
C16	1200Fb-1.2E
C20	1450Fb-1.3E
C24	1650Fb-1.5E
C27 <sup>(1)</sup>	1800Fb-1.6E
C30 <sup>(2)</sup>	1950Fb-1.7E, 2100Fb-1.8E, 2400Fb-2.0E
C35	2700Fb-2.2E
<sup>(1)</sup> Note: Nominal 2x3 size (38.1 x 63.5 mm) 1800Fb-1.6E is assigned to strength class C24	
<sup>(2)</sup> Note: Nominal 2x3 size (38.1 x 63.5 mm) 1950Fb -1.7E is assigned to strength class C27	

**16.5 RECORDS**

All records shall be kept for at least **10** years.

**16.6 ADDITIONAL QUALIFICATION AND QUALITY CONTROL REQUIREMENTS (EN 14081-2 & EN 14081-3)**

**a) Proof load to  $F_b$**

Specimens shall be tested edgewise with the tension edge selected at random and the estimated weakest cross section positioned where possible within the centre third of the span.

*Note: The span to depth ratio of 21 prescribed in NLGA SPS 2 meets the span to depth ratio of  $18 \pm 3$  of EN 408.*

**b) Determine the Actual Modulus of Elasticity ( $E_p$ )**

In accordance with Clause 10 in EN 408, MOE is determined by measuring the deflection at the span centre relative to the supports, with the tension edge selected at random and the estimated weakest cross section positioned where possible within the centre third of the span.

*Note: The span to depth ratio of 21 prescribed in NLGA SPS 2 meets the span to depth ratio of  $18 \pm 3$  of EN 408.*

**c) Rate of Applied Stress**

The rate of applied stress shall be 110 N/mm<sup>2</sup>/min. If more than one strength class is to be graded in one pass through the machine in production, then these classes shall also be graded in one pass to obtain specimens for the assessment tests.

*Note: The rate of applied stress at 110 N/mm<sup>2</sup>/min is significantly slower than specified in NLGA SPS 2 but is not an upper limit. To be equivalent, SPS 2 would need, for example, to specify cross-head speeds of 2.5 inches/min for 1450Fb-1.3E and 1.7 inches/min for 2400Fb-2.0E.*

## APPENDICES (Informative)

### APPENDIX I - REFERENCE MODULUS OF ELASTICITY

Since modulus of elasticity, determined in a bending test, is affected by machine deflection measuring techniques and loading application procedure, it is necessary to define a single reference procedure for calibration of quality control equipment.

The reference modulus of elasticity (E) is determined in accordance with ASTM D198 - *Standard Method of Static Test of Timbers in Structural Sizes*. The modulus of elasticity data is adjusted to 15% moisture content and to a 21 to 1 span-to-depth ratio, which is in accordance with ASTM D2915 - *Standard Methods for Evaluating Allowable Properties for Grades of Structural Lumber*.

### APPENDIX II - CORRECTION FACTORS FOR EDGE MODULUS OF ELASTICITY

In cases where the length of the test specimen is such that only a span to depth ratio of less than 21 is possible, the following correction factors are applied to the edge modulus of elasticity. For span-to-depth ratios between 10 and 21, other than those in Table 18, factors can be obtained by linear interpolation.

TABLE 18 - CORRECTION FACTORS FOR MOE

Correction Factors for Edge Modulus of Elasticity	
Span to Depth Ratio	Multiply MOE Value by: <sup>(1)</sup>
20	1.003
19	1.007
18	1.012
17	1.017
16	1.023
15	1.032
14	1.041
13	1.053
12	1.069
11	1.086
10	1.113

<sup>(1)</sup> Values adapted from ASTM D2915, Section X4.



**APPENDIX III - MECHANICAL PROPERTY DESCRIPTIONS**

The fibre stress in bending ( $F_b$ ) is derived from the lower fifth percentile of short-term bending strength assigned to a MSR grade. The  $F_b$  is indicated by a value in pounds per square inch preceding the symbol “ $Fb$ ”. The  $E_g$  is the mean modulus of elasticity assigned to the MSR grade. The  $E_g$  is indicated by a value in units of one million pounds per square inch, followed by the symbol “ $E$ ”. The tensile strength ( $F_t$ ) is derived from the lower fifth percentile of short-term tensile strength assigned to the MSR grade. The  $F_t$  is indicated by a value in pounds per square inch preceding the symbol “ $Ft$ ”.

The  $E$  rating is the rated modulus of elasticity in millions of pounds per square inch for the grade when measured on edge.

Grading machines are adjusted so that the mean  $E$  of the output will equal or exceed the  $E$  level shown on the grade mark.  $F_b$  indicates the fibre stress in bending applicable to lumber loaded on edge. Fibre stress in bending design values are based on the correlation of the modulus of rupture to  $E$ . Grading machine output is controlled by testing pieces and adjusting the grading machine so that the minimum assigned fibre stress in bending value, derived from a 5% exclusion level of modulus of rupture is met after applying the same reduction factors as are applied to visually graded lumber in accordance with ASTM D245.

Design values in Tables 2 and 3 for compression parallel to grain ( $F_c$ ) and tensile strength ( $F_t$ ) are based on the testing of MSR lumber. Horizontal shear ( $F_v$ ) values for MSR lumber and MEL are the same as assigned by ASTM methods to visually graded NO. 2 lumber of the appropriate species or species group.

**APPENDIX IV - CUSUM PARAMETERS FOR MOE QUALITY CONTROL**

**TABLE 19 - CUSUM PARAMETERS FOR MGL CATEGORIES**

E Value (x 10 <sup>6</sup> )	E Designation	W			X	Y	Z
		MSR	MEL	E-LAM			
1.2E	120	98	90	-	1150	120	333
1.3E	130	107	98	-	1250	141	356
1.4E	140	115	105	-	1350	163	378
1.5E	150	123	113	121	1450	186	402
1.6E	160	131	120	130	1550	211	428
1.7E	170	139	128	139	1650	236	455
1.8E	180	147	135	148	1750	262	483
1.9E	190	156	143	158	1850	288	511
2.0E	200	164	150	167	1950	316	542
2.1E	210	172	158	177	2050	344	574
2.2E	220	180	165	186	2150	372	606
2.3E	230	189	173	196	2250	400	638
2.4E	240	197	180	206	2350	428	670
2.5E	250	205	187	216	2450	456	702
2.6E	260	213	195	226	2550	484	734

*Note: Table adapted from Warren, W.G. 1978. Recent Developments in Statistical Quality-Control Procedures for MSR. Environment Canada, Forestry Directorate, Western Forest Products Laboratory. Vancouver, BC.*

APPENDIX V - OUT-OF-CONTROL FLOW CHARTS FOR MGL VERIFICATION

FIGURE 2 – VERIFICATION DECISION FLOWCHART

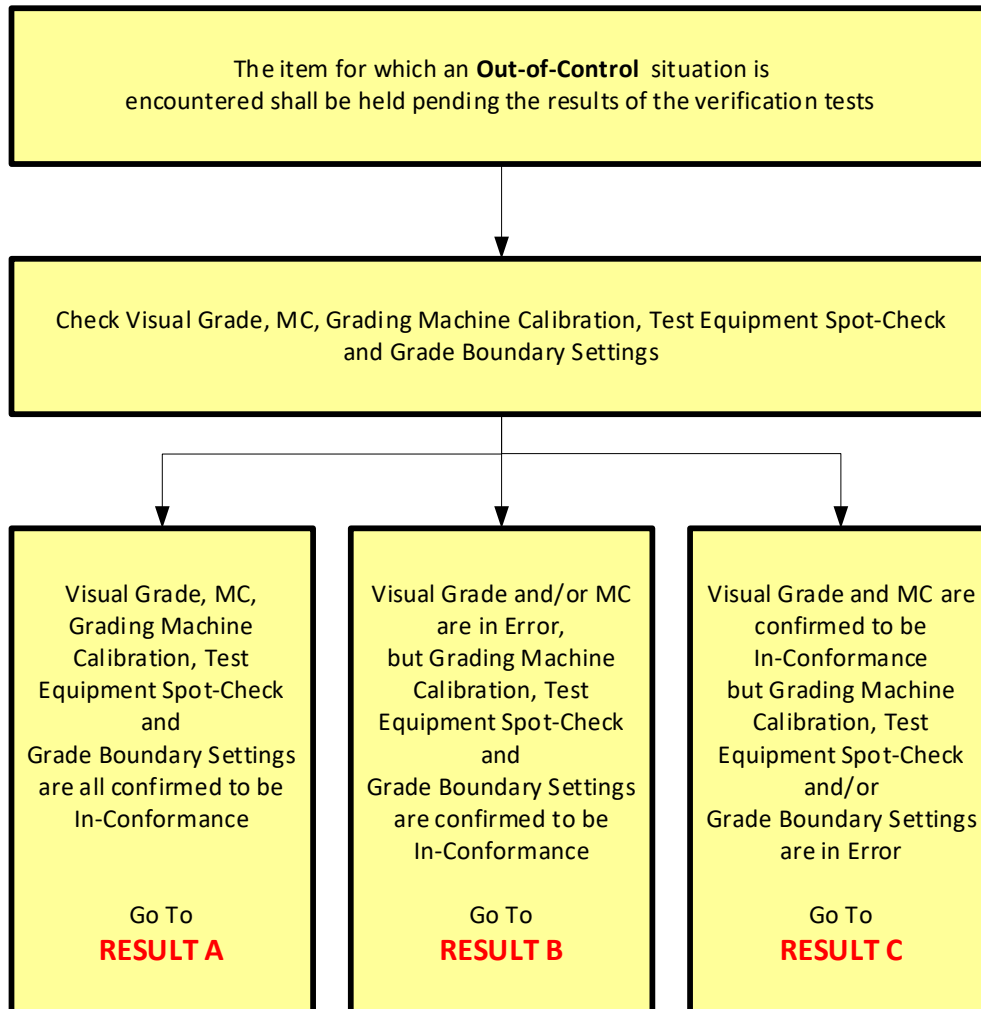

## APPENDIX V (CONT.) - OUT-OF-CONTROL FLOW CHARTS FOR MGL VERIFICATION

FIGURE 3 – RESULT A DECISION FLOWCHART

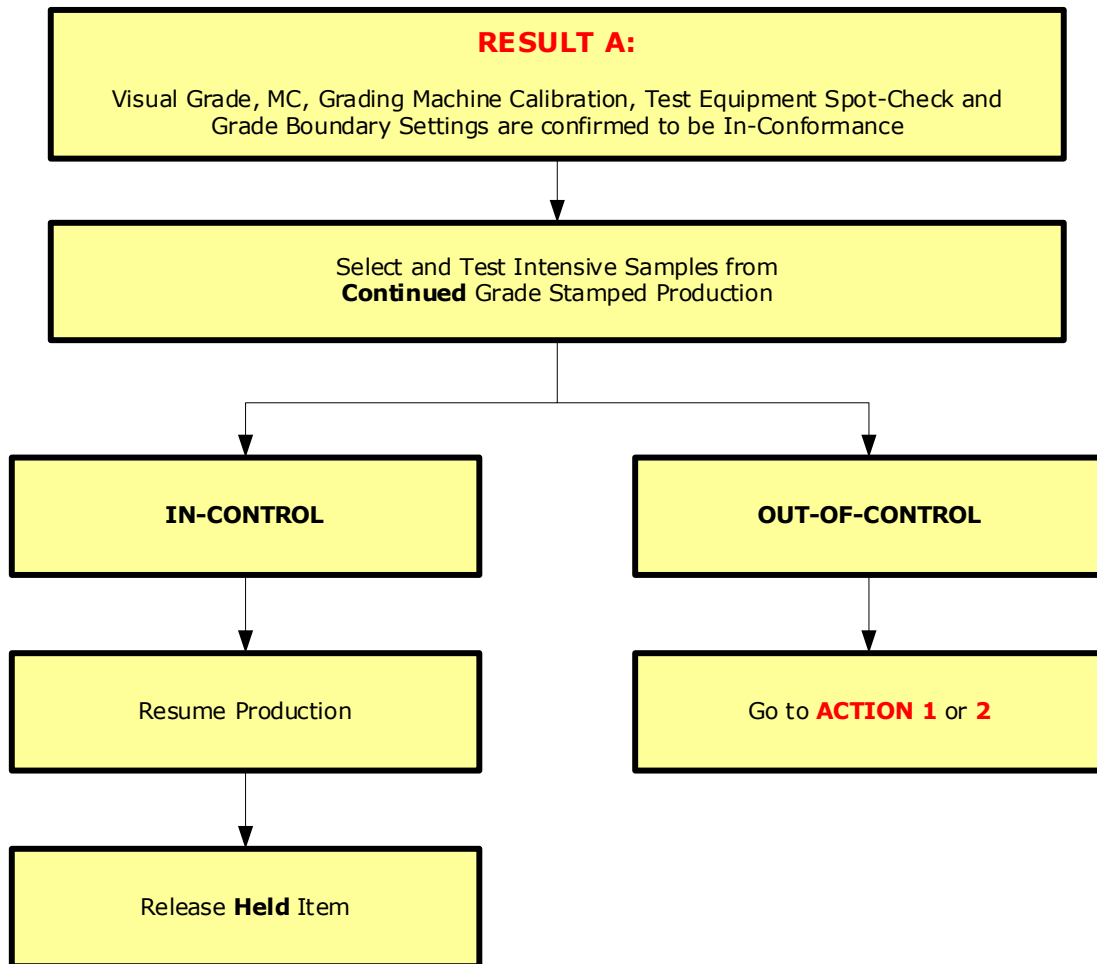

APPENDIX V (CONT.) - OUT-OF-CONTROL FLOW CHARTS FOR MGL VERIFICATION

FIGURE 4 – RESULT B DECISION FLOWCHART

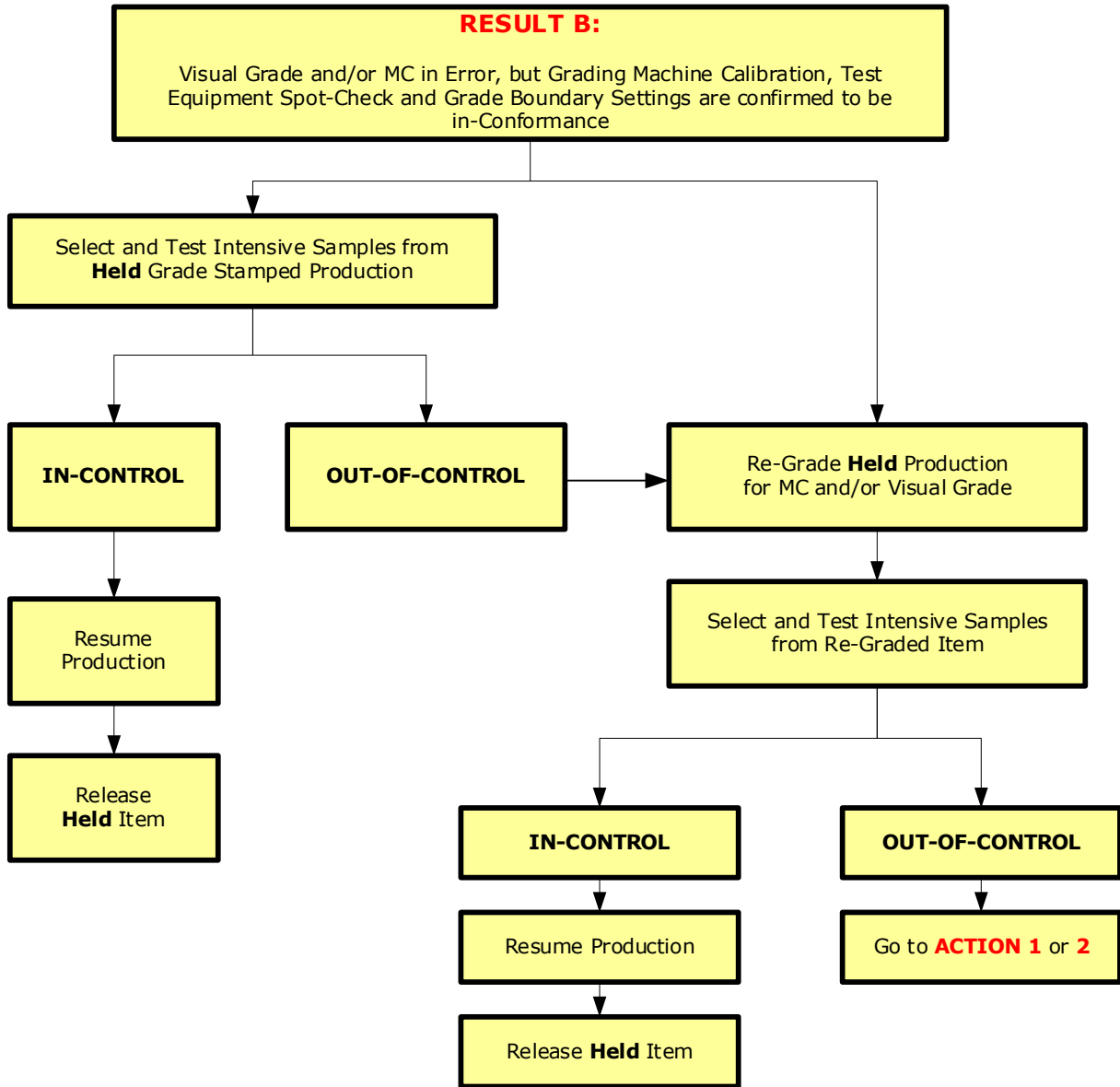

APPENDIX V (CONT.) - OUT-OF-CONTROL FLOW CHARTS FOR MGL VERIFICATION

FIGURE 5 – RESULT C DECISION FLOWCHART

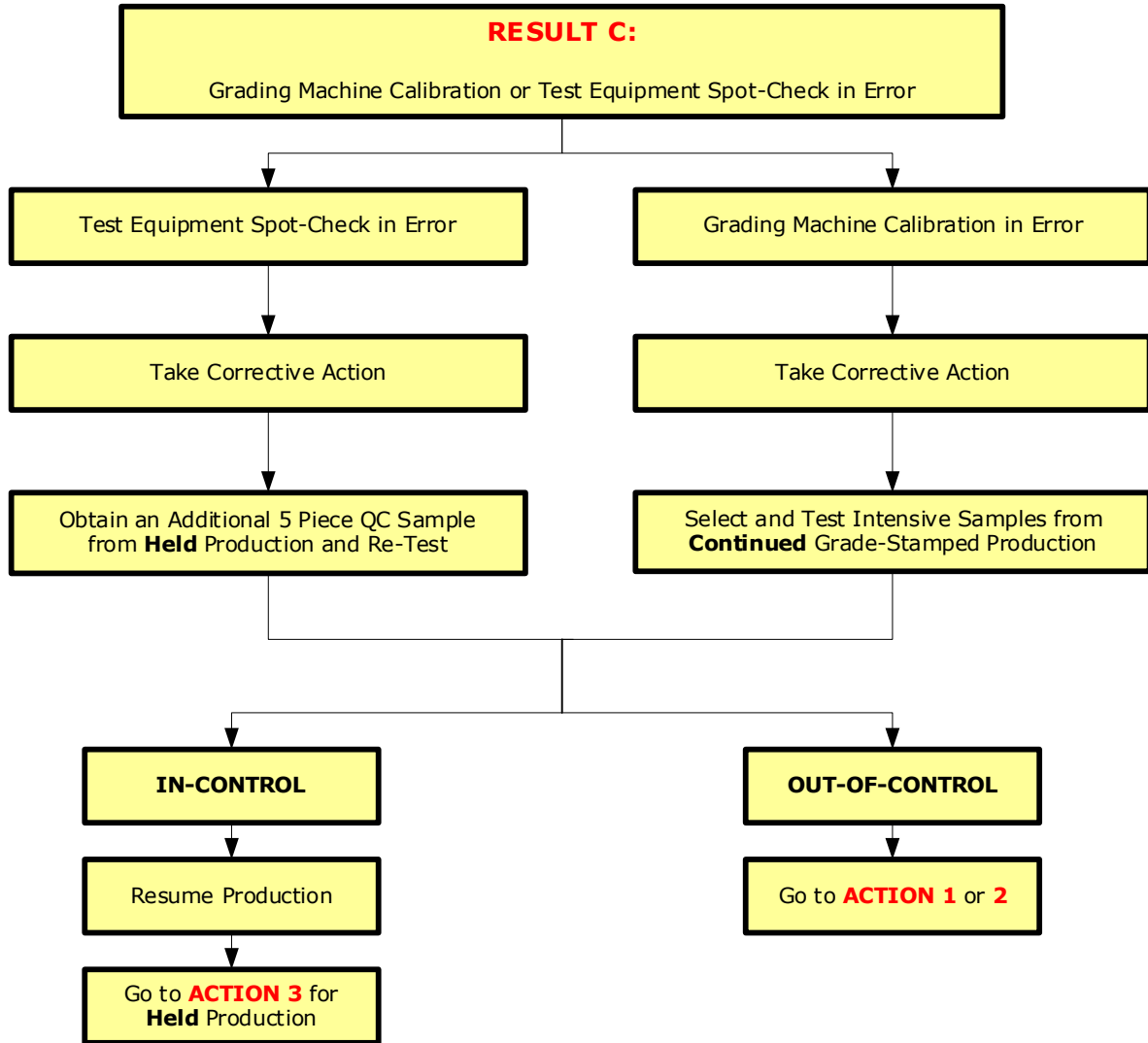

APPENDIX V (CONT.) - OUT-OF-CONTROL FLOW CHARTS FOR MGL VERIFICATION

FIGURE 6 – ACTION 1 DECISION FLOWCHART

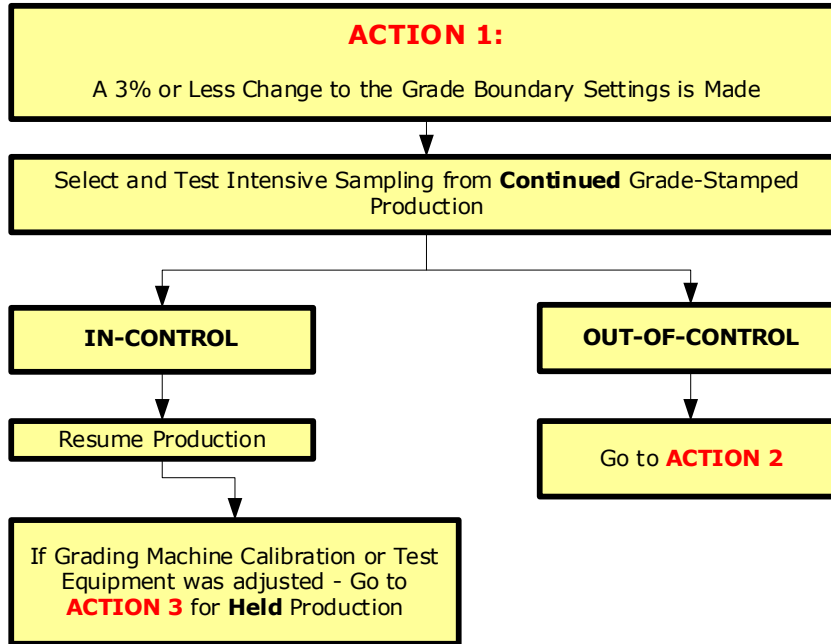
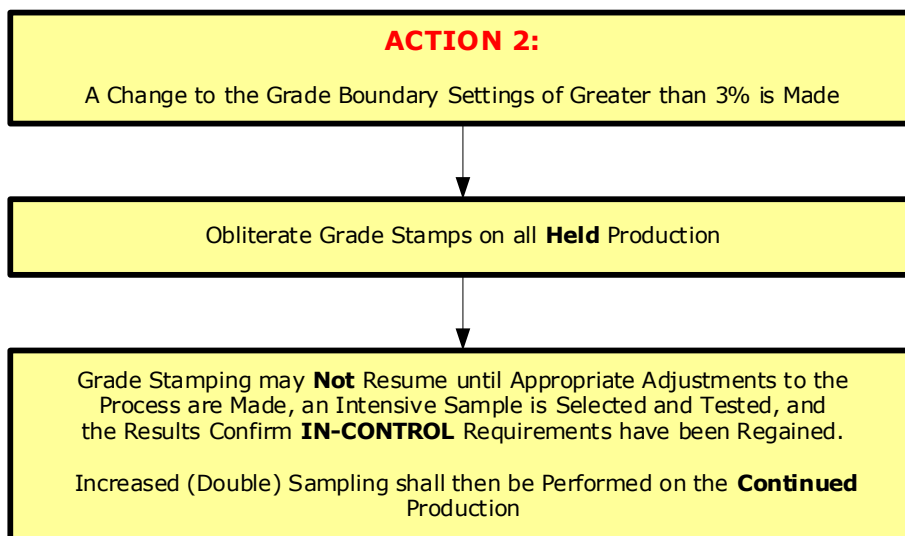
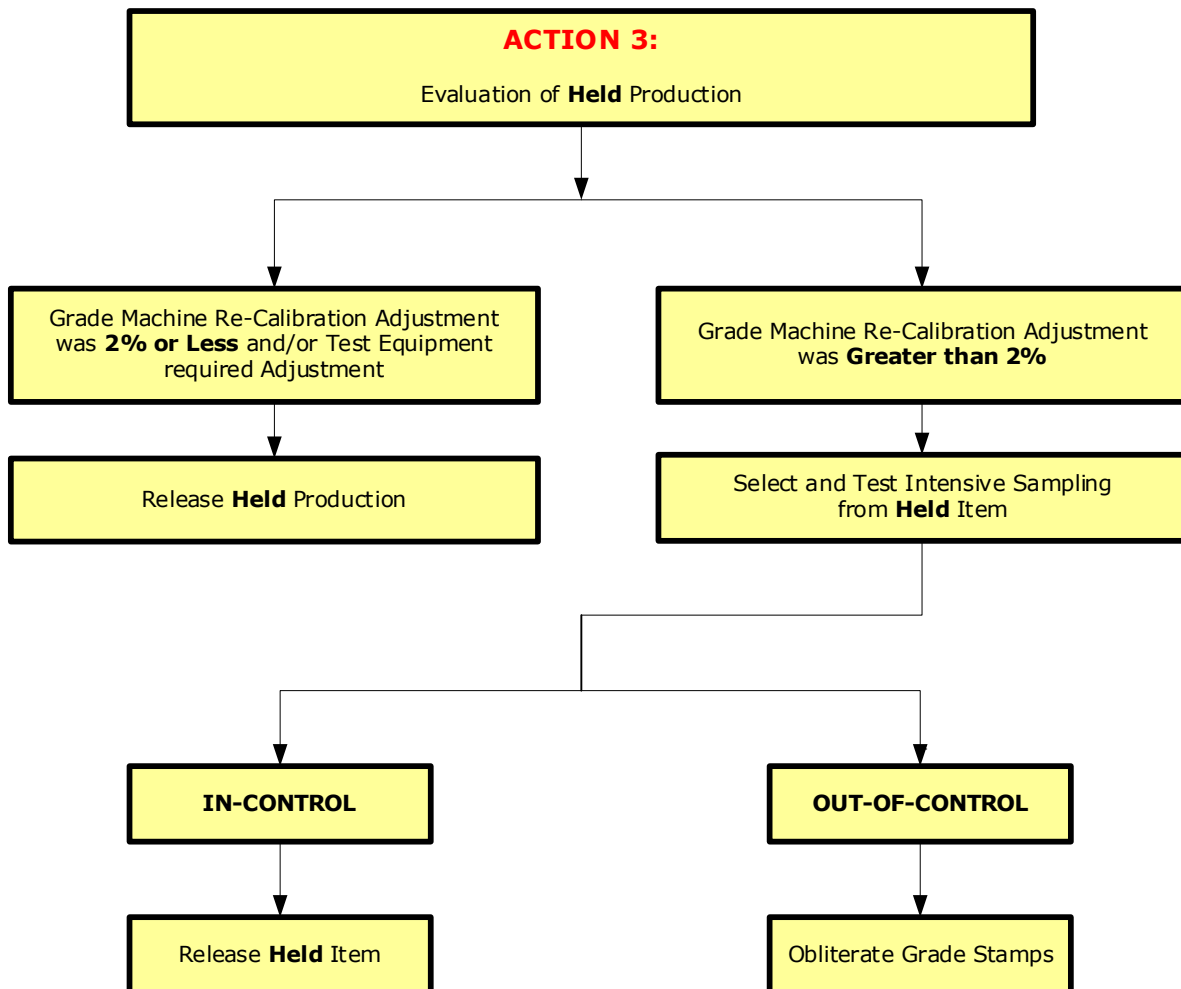

FIGURE 7 – ACTION 2 DECISION FLOWCHART



## APPENDIX V (CONT.) - OUT-OF-CONTROL FLOW CHARTS FOR MGL VERIFICATION

FIGURE 8 – ACTION 3 DECISION FLOWCHART



## APPENDIX VI - COMMENTARY ON QUALITY CONTROL SAMPLING FREQUENCY

In Section 2.1 – SAMPLING a) and Section 14.2.2 – SAMPLING FREQUENCY, the Standard requires that one 5-specimen sample shall be generated for quality control from every four hours or less of production. For partial or longer shifts, or shifts where different items are produced, the intent is that each item is still fully sampled for quality control. The following are sampling frequency examples for non-standard production scenarios:

- a) For production shifts longer than the standard 8-hour shift, the third 4-hour period may be split between the remaining hours of the first full production shift and the beginning hours of the second full production shift.

For example, for a facility running 10-hour shifts, the 5-specimen sample could be collected for every 4-hour period over a combined 2-shift (20-hour) period. The 4-hour period that overlaps the two shifts would require collection of 2 or 3 specimens in the last 2 hours of the first production shift and 2 or 3 specimens in the first 2 hours of the second production shift to total a 5-specimen sample for the full 4-hour period. In the case of 12-hour shifts, three 5-specimen samples would be collected for each of the 4-hour periods during the shift.

- b) At the end of a production run, if the production of an item carries over into the next 4-hour sampling period by no more than a 1-hour period, additional QC sampling is not required, but the cause and length of carry-over time must be documented. If the production carry-over exceeds a 1-hour period into the next 4-hour sampling period, then a new 5-specimen sample must be collected.

## APPENDIX VII - COMMENTARY ON INCREASED (DOUBLE) SAMPLING FREQUENCY

The Section 2.1 – SAMPLING b) definition of increased (double) sampling states that two 5-specimen samples shall be generated from every 4 hours or less of production, for a period of 3 production shifts. A production shift is based on the standard 8-hour shift, thus increased (double) sampling generates twelve 5-specimen samples over 24 hours of production for a total of 60 specimens.

For partial or longer shifts, or shifts where different items are produced, the intent is that each item is still fully sampled. The following are increased (double) sampling frequency examples for non-standard production shifts:

- a) For production shifts longer than 8 hours, the basic requirement of two 5-specimen samples generated for every 4 hours of production over 24 hours still applies. For example:
- A 12-hour production shift would generate six 5-specimen samples (two samples for every 4-hour period of production) for the first full shift and six 5-specimen samples for the second full shift, totaling twelve 5-specimen samples over 24 hours of production (60 specimens).

- For 10-hour production shifts, sample collection would be spread over two full shifts and the first 4 hours of the third shift as follows:

First production shift: two 5-specimen samples each from the first and second 4-hour periods and one sample for the last 2-hour period of production,

Second Production shift: one sample from the first 2-hour period and two samples each from the next two 4-hour periods, and

Third production shift: two samples from the first 4-hour period.

Over the first and second full shifts and third partial shift, a total of twelve 5-specimen samples would be collected over 24 hours of production (60 specimens).

- b) In the case where the production period does not run for the required three production shifts totaling 24 hours, the required twelve 5-specimen samples must be generated in the available (shorter) production period.

Increased (double) sampling would be completed before production of an item can be released.



**APPENDIX VIII - COMMENTARY ON CONTENTS OF A QUALITY CONTROL MANUAL**

The Quality Control (QC) Manual specifies, in writing, one or more sets of facility operating conditions that are known to result in a product that is in continuous conformance with the requirements of this Standard. The qualification applies only to product(s) produced within the specified limits of the QC Manual.

The details of the QC Manual will vary with the process used. Some aspects of it may be common to all lumber sizes, grades, and species groups, while other aspects may vary with specific sizes, grades and/or species groups.

The QC Manual provides details of all test procedures used, the wood failure criteria used (if any) and the records to be kept of in-process checks that are made.

The QC Manual describes the manufacturing operation, broken down by station. For each station in the sequence of manufacture, a description is required of the function performed by the equipment, the skills the operator requires, the responsibility of the operator in control of that station, and what checks are instituted (if required) to ensure that the equipment and operator are performing within the desired limits. Provisions must be outlined for the absence of any operator with specialized skills essential to the process.

Examples of typical stations are:

- a) **Grading machine setup:** station where grading machine (boundary) settings are adjusted and monitored, and
- b) **Off-line quality control test equipment:** station where quality control specimens are tested.

**APPENDIX IX - CUSUM PARAMETERS FOR SPECIFIC GRAVITY CONTROL**

TABLE 20 – CUSUM PARAMETERS FOR MONITORING SPECIFIC GRAVITY

S-P-F (0.42 SG)	D Fir-L (N) (0.49 SG)	Hem-Fir (N) (0.44 SG)	N Species (0.35 SG)	Normal location, zero start									
				Mean	Std Dev	AQL	Std Err	RQL	k	h (DI)	h* (DI)	h + h*	
				n = 5									
				CoV = 12%									
				AQL Int = 0.005									
				RQL Int = 0.040									
				L = 150									
				L* = 5									
									X	Y		Z	
0.42				0.420	0.050	0.415	0.022	0.380	0.398	0.049	0.074	0.123	
			0.43	0.430	0.052	0.425	0.023	0.390	0.408	0.051	0.074	0.125	
0.44		0.44		0.440	0.053	0.435	0.023	0.400	0.418	0.053	0.074	0.127	
			0.45	0.450	0.054	0.445	0.024	0.410	0.428	0.056	0.074	0.130	
0.46		0.46		0.460	0.055	0.455	0.024	0.420	0.438	0.058	0.074	0.133	
			0.47	0.470	0.056	0.465	0.025	0.430	0.448	0.061	0.075	0.136	
0.48		0.48		0.480	0.058	0.475	0.025	0.440	0.458	0.063	0.075	0.138	
	0.49		0.49	0.490	0.059	0.485	0.026	0.450	0.468	0.064	0.075	0.139	
0.50		0.50		0.500	0.060	0.495	0.027	0.460	0.478	0.069	0.075	0.144	
	0.51		0.51	0.510	0.061	0.505	0.027	0.470	0.488	0.071	0.076	0.147	
0.52		0.52		0.520	0.062	0.515	0.028	0.480	0.498	0.074	0.076	0.149	
	0.53		0.53	0.530	0.064	0.525	0.028	0.490	0.508	0.077	0.077	0.153	
0.54		0.54		0.540	0.065	0.535	0.029	0.500	0.518	0.079	0.076	0.155	
	0.55		0.55	0.550	0.066	0.545	0.029	0.510	0.528	0.082	0.077	0.159	
0.56		0.56		0.560	0.067	0.555	0.030	0.520	0.538	0.085	0.077	0.162	
	0.57		0.57	0.570	0.068	0.565	0.030	0.530	0.548	0.087	0.077	0.164	
0.58		0.58		0.580	0.070	0.575	0.031	0.540	0.558	0.090	0.077	0.168	
	0.59		0.59	0.590	0.071	0.585	0.031	0.550	0.568	0.093	0.077	0.171	
0.60		0.60		0.600	0.072	0.595	0.032	0.560	0.578	0.096	0.078	0.173	

**Note:** Table adapted from “Development of Recommended Quality Control Limits for MSR Lumber Specific Gravity and Guidelines for Use, NLGA Internal SPS 2 background document, 2003”.

## NLGA - SPS 2

**June 1, 2025**

---

The NLGA Special Products Standard for Machine Graded Lumber (**SPS 2**) consists of **40** pages.

This Standard, like all NLGA Standards, is subject to periodic review, and may be amended from time to time.

To identify or obtain the most current version of NLGA – SPS 2, or any Supplements or Errata, check the publication section of the NLGA website at [www.nlga.org](http://www.nlga.org).